

**TRINITY GLASS**  
INTERNATIONAL

33615 1st Way S, Federal Way, WA 98003

**OPAQUE FIBERGLASS  
"IMPACT" DOOR with SIDELITE(S)  
OUTSWING**

GENERAL NOTES

1. This product has been evaluated and is in compliance with the 5th Edition (2014) Florida Building Code (FBC) structural requirements including the "High Velocity Hurricane Zone" (HVHZ).
2. Product anchors shall be as listed and spaced as shown on details. Anchor embedment to base material shall be beyond wall dressing or stucco.
3. When used in the "HVHZ" this product complies with Section 1626 of the Florida Building Code and does not require an impact resistant covering.
4. When used in areas outside of the "HVHZ" requiring wind borne debris protection this product complies with Section 1609.1.2 of the FBC and does not require an impact resistant covering. This product meets missile level "D" and includes Wind Zone 4 as defined in ASTM E1996 and Section 1609.1.2.2 of the FBC.
5. For 2x stud framing construction, anchoring of these units shall be the same as that shown for 2x buck masonry construction.
6. Site conditions that deviate from the details of this drawing require further engineering analysis by a licensed engineer or registered architect.
7. This product meets water infiltration requirements for "HVHZ".

**TABLE OF CONTENTS**

SHEET#	DESCRIPTION
1	Typical elevations, design pressures & general notes
2	Door panel details
3	Sidelite panel details and glazing details
4	Elevations
5	Horizontal cross sections
6	Vertical cross sections
7	Vertical cross sections
8	Horizontal and vertical cross sections
9	Buck anchoring
10	Buck anchoring
11	Frame anchoring 2X buck masonry construction
12	Frame anchoring 2X buck masonry construction
13	Frame anchoring 1X buck masonry construction
14	Frame anchoring 1X buck masonry construction
15	Components
16	Bill of materials

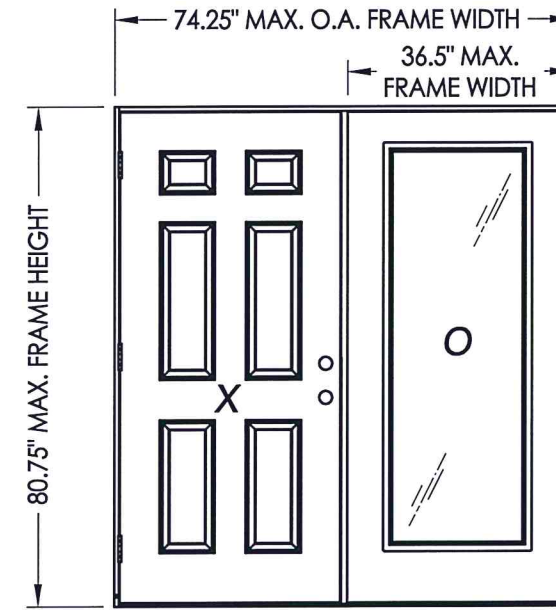

**CONTINUOUS HEADER AND SILL**

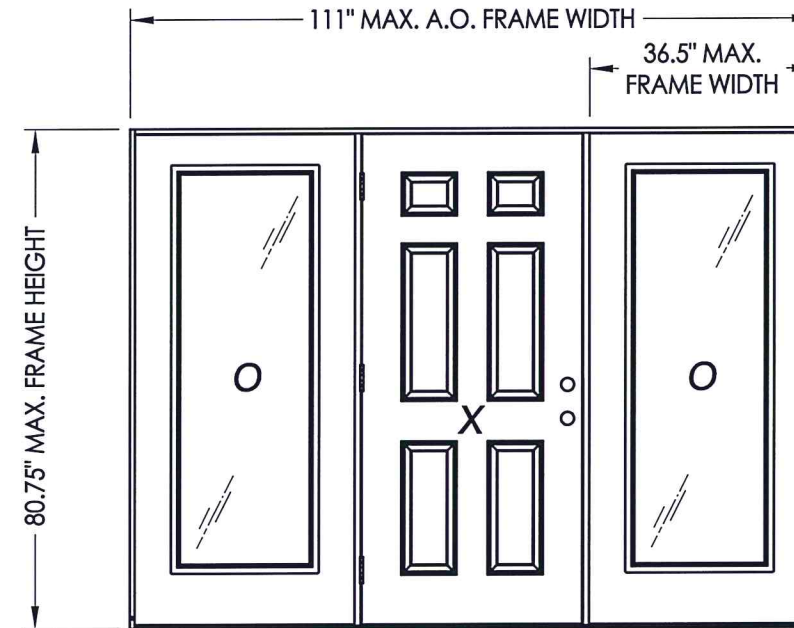

**CONTINUOUS HEADER AND SILL**

CONFIGURATION	MAX. FRAME DIMENSION	JAMB TYPE	DESIGN PRESSURE (PSF)	
			POSITIVE	NEGATIVE
OX/XO	74.25" x 80.75"	WOOD	+60.0	-70.0
		FIBERGLASS/COMP	+55.0	-55.0
OXO	111.0" x 80.75"	WOOD	+55.0	-55.0
		FIBERGLASS/COMP	+55.0	-55.0

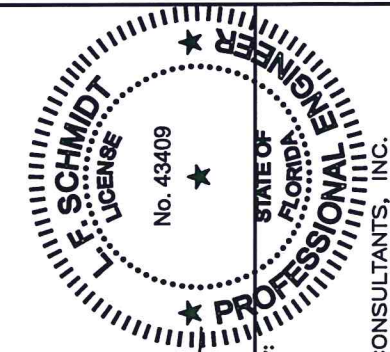

Documents Prepared By:  
Lyndon F. Schmidt  
P.E. No. 43409

**PROFESSIONAL ENGINEER**  
STATE OF FLORIDA  
BUILDING CONSULTANTS, INC.  
P.O. Box 230, Valrico, FL 33595  
Phone No.: 813.659.9197  
FBPE C.A. No. 9813

PRODUCT:	TRINITY GLASS INT'L
PART OR ASSEMBLY:	TYPICAL ELEVATION, DESIGN PRESSURES & GENERAL NOTES
DATE:	02/27/12
SCALE:	N.T.S.
DWG. BY:	JK
CHK. BY:	LFS
DRAWING NO.:	FL-15255.2
SHEET	1 OF 16

R:\Clients\Trinity PERMANENT\Florida Product Approvals\FL-15255\C - Drawings\FL-15255\FL-15255.1-4.dwg, 2.2

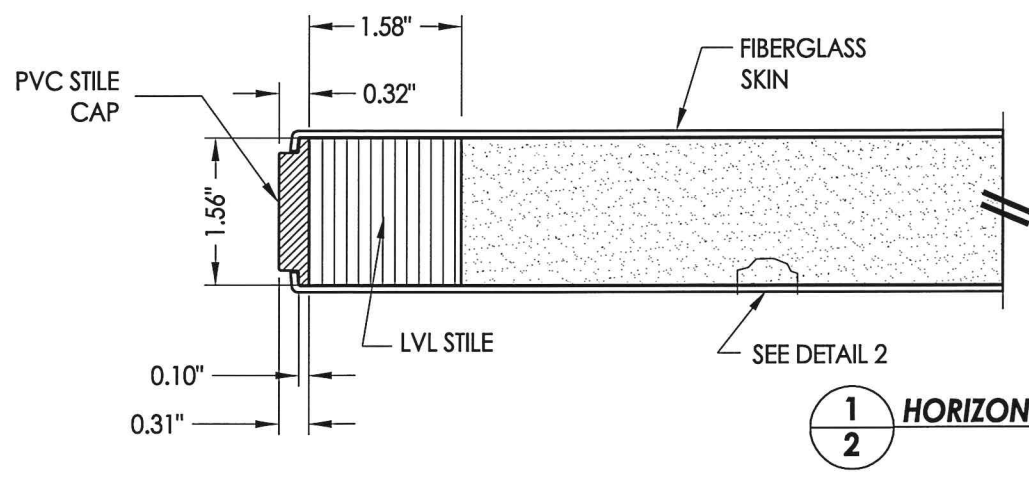

**1**  
**2** **HORIZONTAL CROSS SECTION**

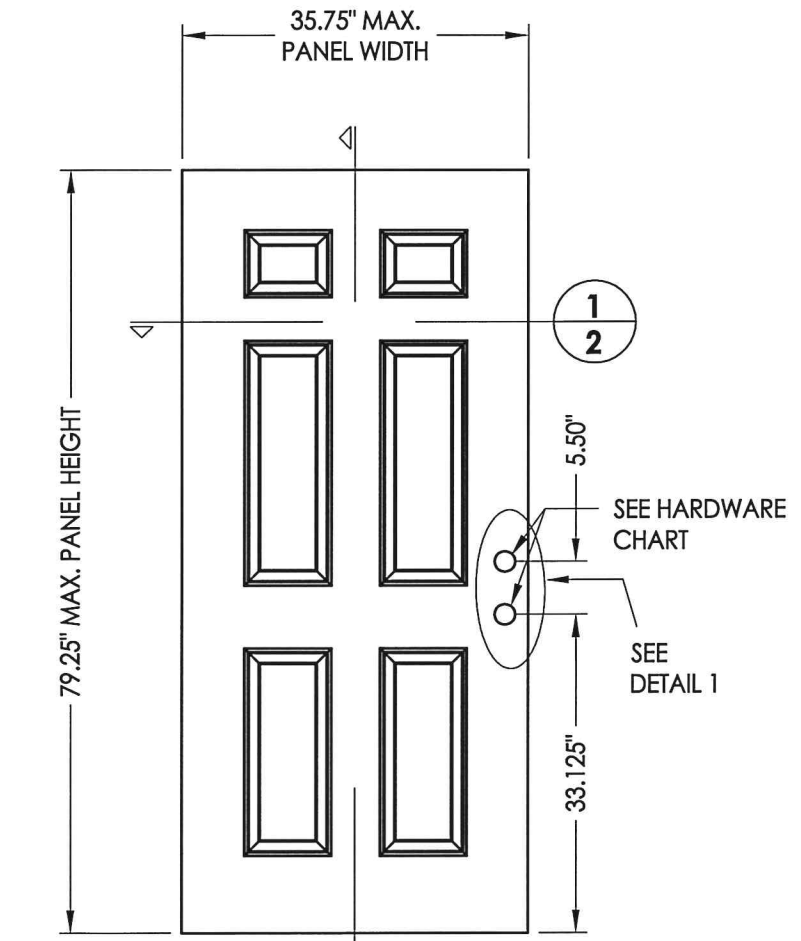
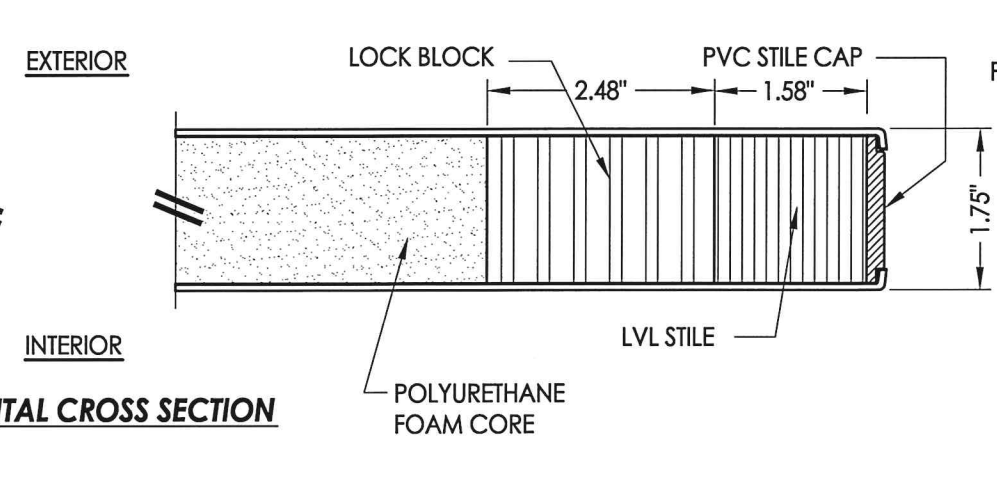

**40** **OPAQUE DOOR**

DOOR SKIN: 0.079\"/>

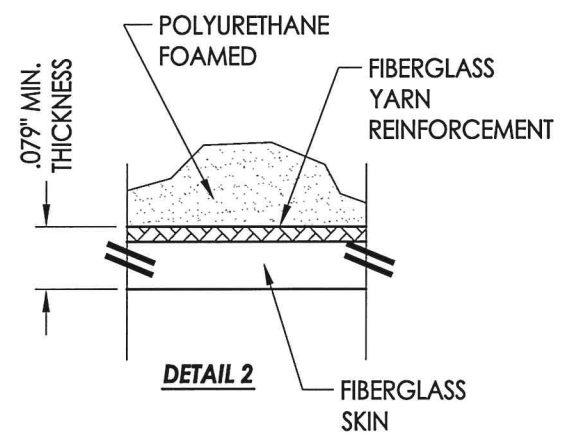

**DETAIL 2**

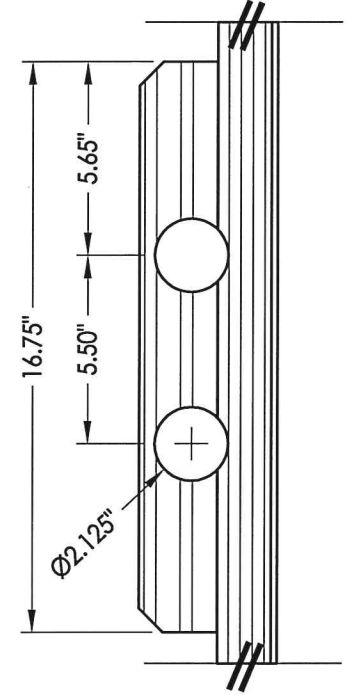

**DETAIL 1**

HARDWARE CHART	
MANUFACTURER	MODEL
KWIKSET	KNOB: SIGNATURE SERIES DEADBOLT: SIGNATURE SERIES (980)

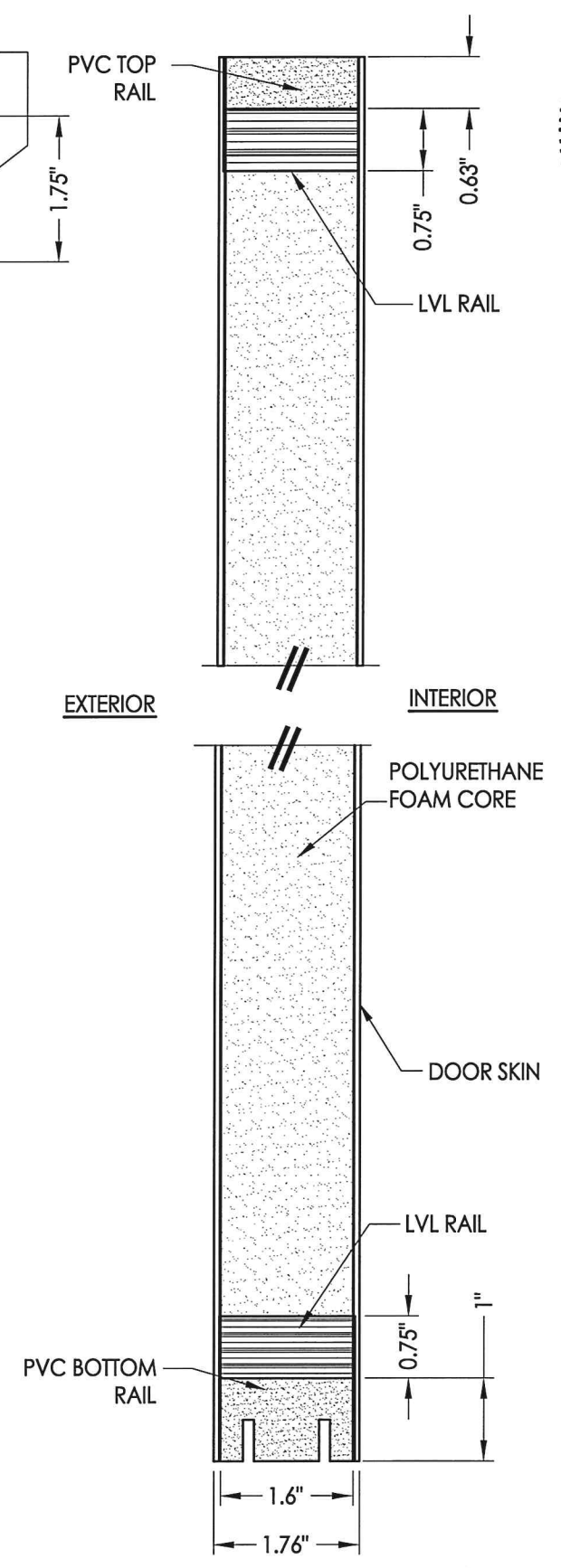

**2**  
**2** **VERTICAL CROSS SECTION**

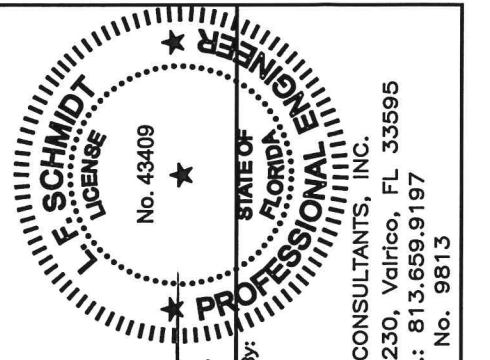

Documents Prepared By: *LFS*  
Lyndon F. Schmidt  
P.E. No. 43409  
5.11.15  
STATE OF FLORIDA  
PROFESSIONAL ENGINEER  
R.W. BUILDING CONSULTANTS, INC.  
P.O. Box 230, Vairico, FL 33595  
Phone No.: 813.659.9197  
FBPE C.A. No. 9813

PRODUCT:	TRINITY GLASS INT'L
PART OR ASSEMBLY:	DOOR PANEL DETAILS
DATE:	02/27/12
SCALE:	N.T.S.
DWG. BY:	JK
CHK. BY:	LFS
DRAWING NO.:	FL-15255.2
SHEET	2 OF 16

R:\Clients\Trinity PERMANENT\Florida Product Approvals\FL-15255\C - Drawings\FL-15255\FL-15255.1-4.dwg, 3.2

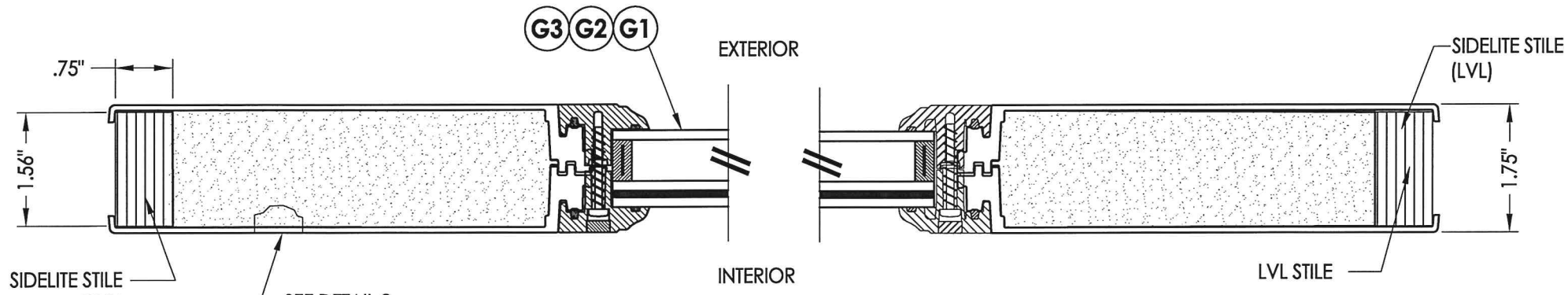

**1 HORIZONTAL CROSS SECTION**

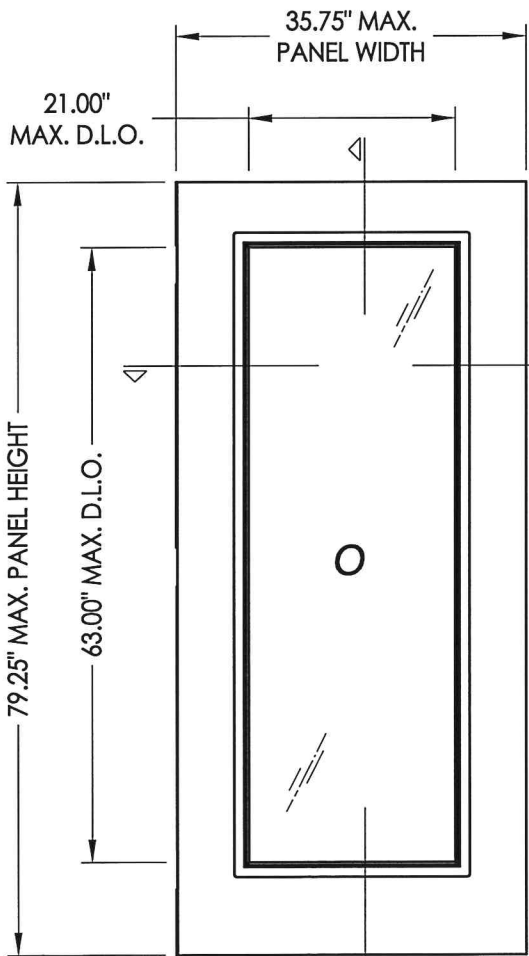

**2 3**

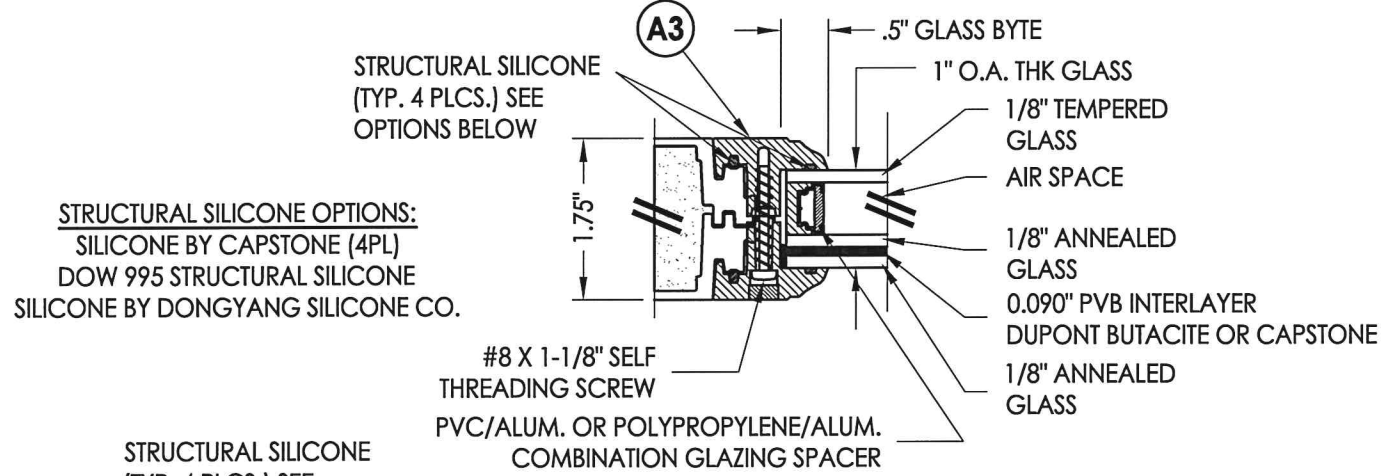

**G2 GLAZING DETAIL**

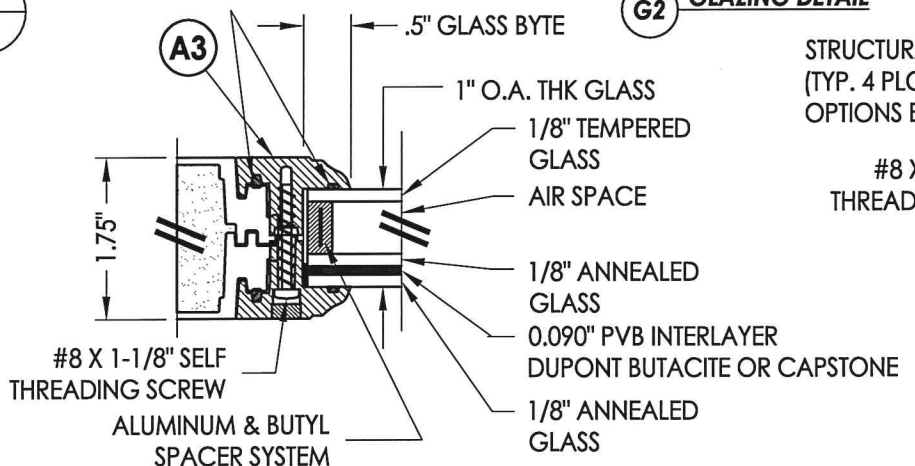

**G1 GLAZING DETAIL**

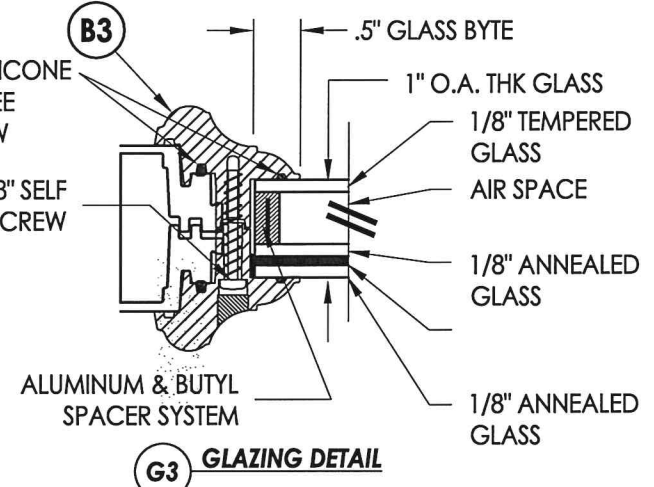

**G3 GLAZING DETAIL**

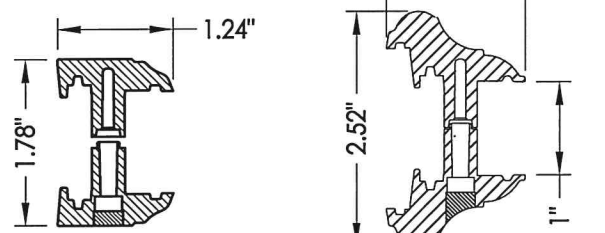

**A3 FLUSH GLAZED FRAME**  
ABS or PC/ASA

**B3 MAHOGANY LITE FRAME**  
ABS or PC/ASA

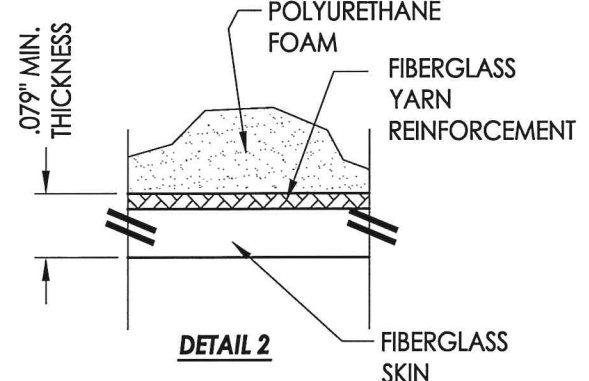

**DETAIL 2**

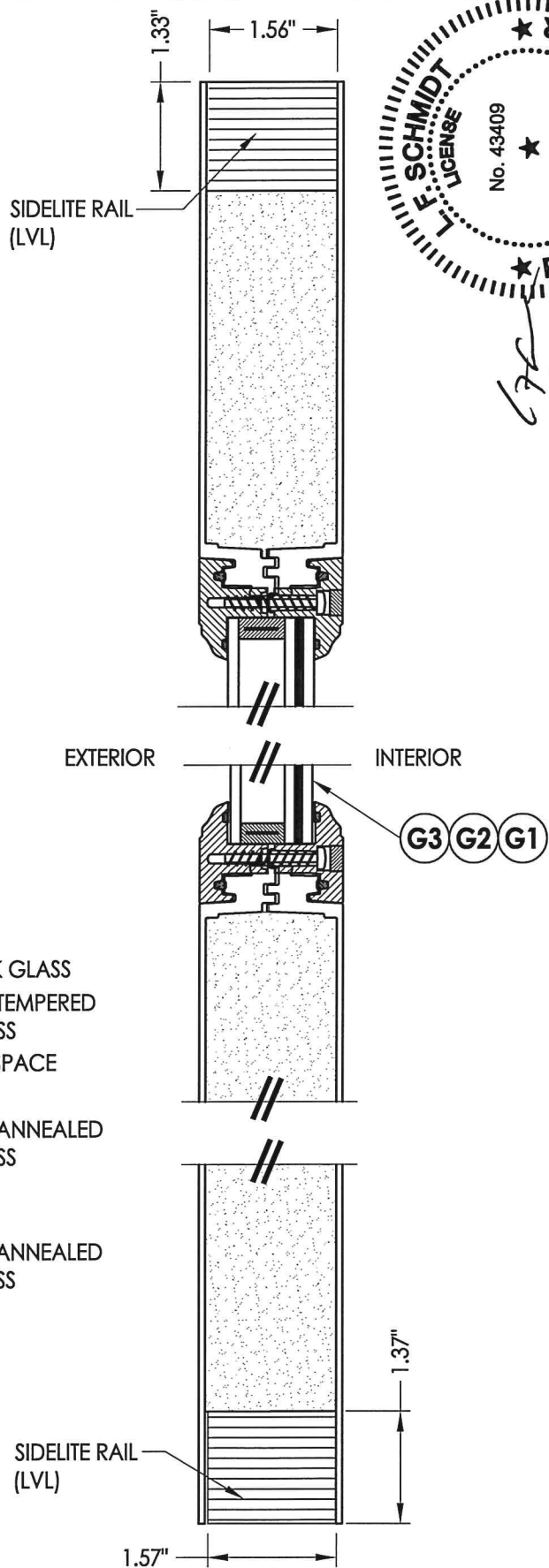

**2 3 VERTICAL CROSS SECTION**

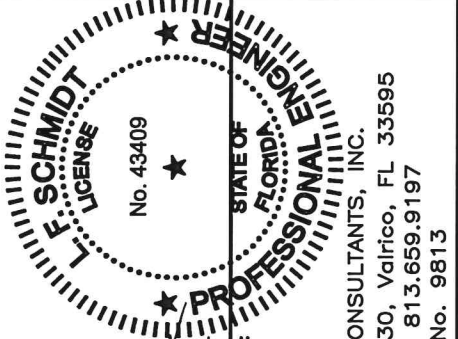

Documents Prepared By:  
Lyndon F. Schmidt  
P.E. No. 43409

RW BUILDING CONSULTANTS, INC.  
P.O. Box 230, Vairico, FL 33595  
Phone No.: 813.659.9197  
FBPE C.A. No. 9813

PRODUCT: TRINITY GLASS INT'L

PART OR ASSEMBLY: SIDELITE PANEL DETAILS AND GLAZING DETAILS

NO.	DATE	REVISIONS
1	03/02/15	UPDATE TO 5TH ED. (2014) FBC
JK		BY

DATE: 02/27/12

SCALE: N.T.S.

DWG. BY: JK

CHK. BY: LFS

DRAWING NO.: FL-15255.2

SHEET 3 OF 16

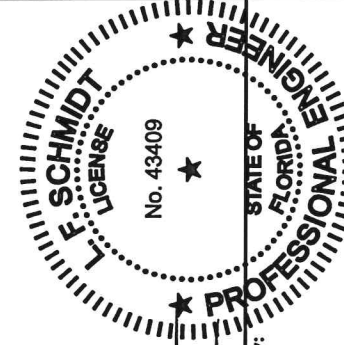
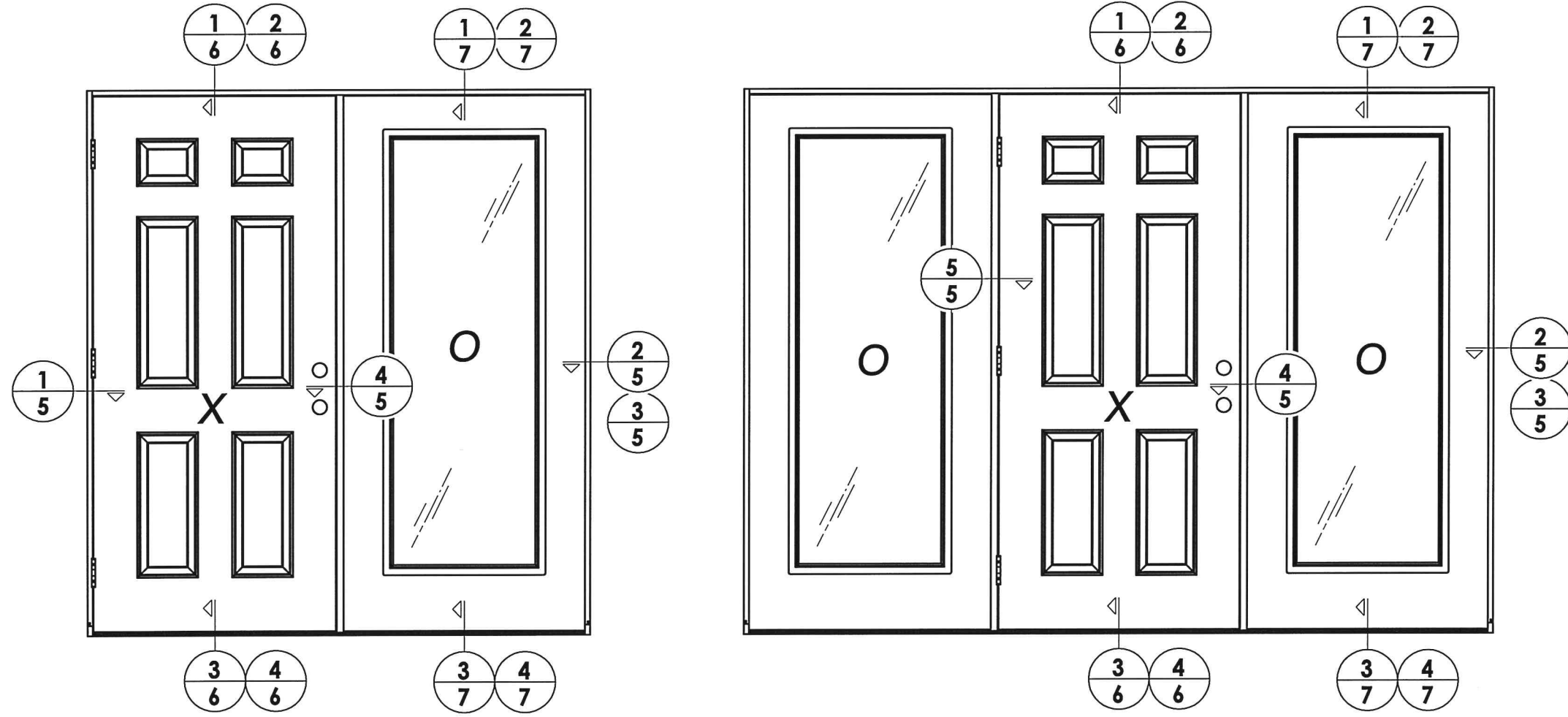

*L.F.S.*  
*S.F.S.*  
 Documents Prepared By:  
 Lyndon F. Schmidt  
 P.E. No. 43409  
**RW** BUILDING CONSULTANTS, INC.  
 P.O. Box 230, Valrico, FL 33595  
 Phone No.: 813.659.9197  
 FBPE C.A. No. 9813

PRODUCT: TRINITY GLASS INT'L  
 PART OR ASSEMBLY: ELEVATIONS

NO.	DATE	REVISIONS	JK	BY
1	03/02/15	UPDATE TO 5TH ED. (2014) FBC	JK	

DATE: 02/27/12  
 SCALE: N.T.S.  
 DWG. BY: JK  
 CHK. BY: LFS  
 DRAWING NO.: FL-15255.2  
 SHEET 4 OF 16

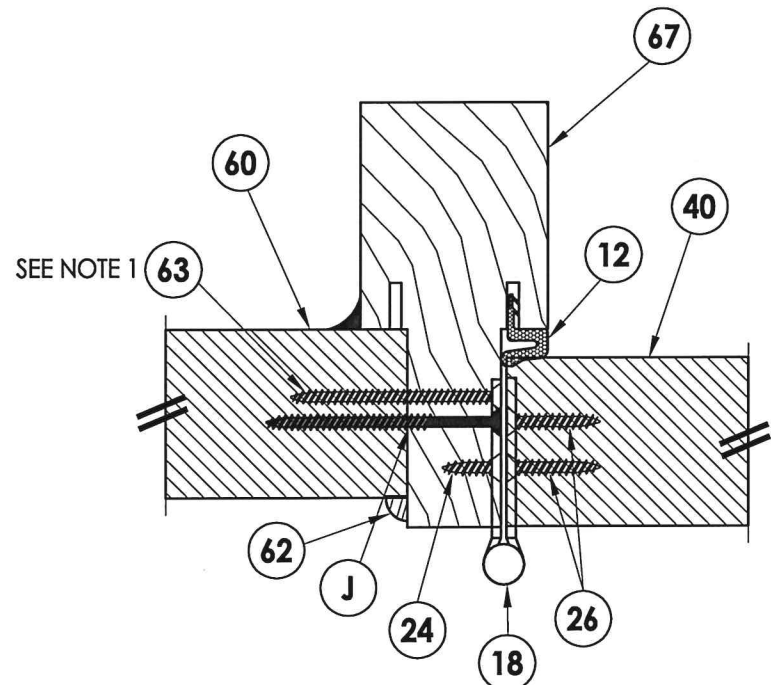

**4**  
**5** HORIZONTAL CROSS SECTION

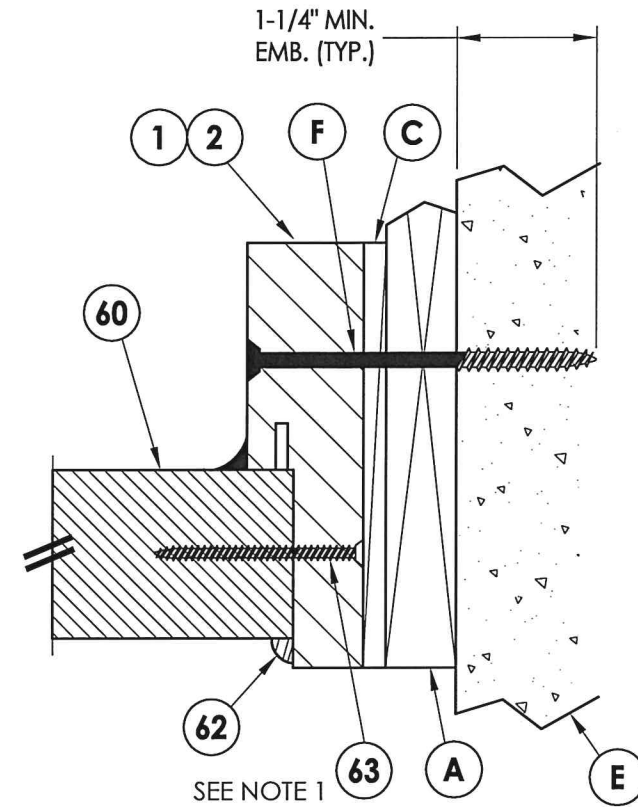

**5**  
**5** HORIZONTAL CROSS SECTION  
Shown w/1X sub-buck

NOTE:  
1. Item #63 located 6" from each end and 3 more equally spaced (5 total).

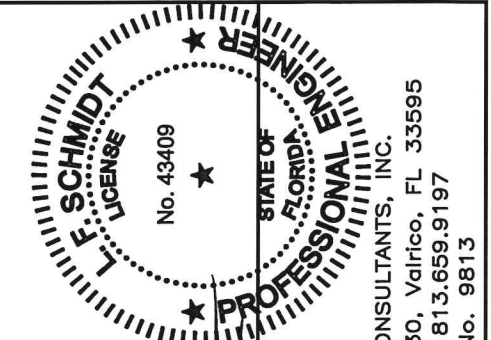

Documents Prepared By:  
Lyndon F. Schmidt  
P.E. No. 43409

**RW** BUILDING CONSULTANTS, INC.  
P.O. Box 230, Valrico, FL 33595  
Phone No.: 813.659.9197  
FBPE C.A. No. 9813

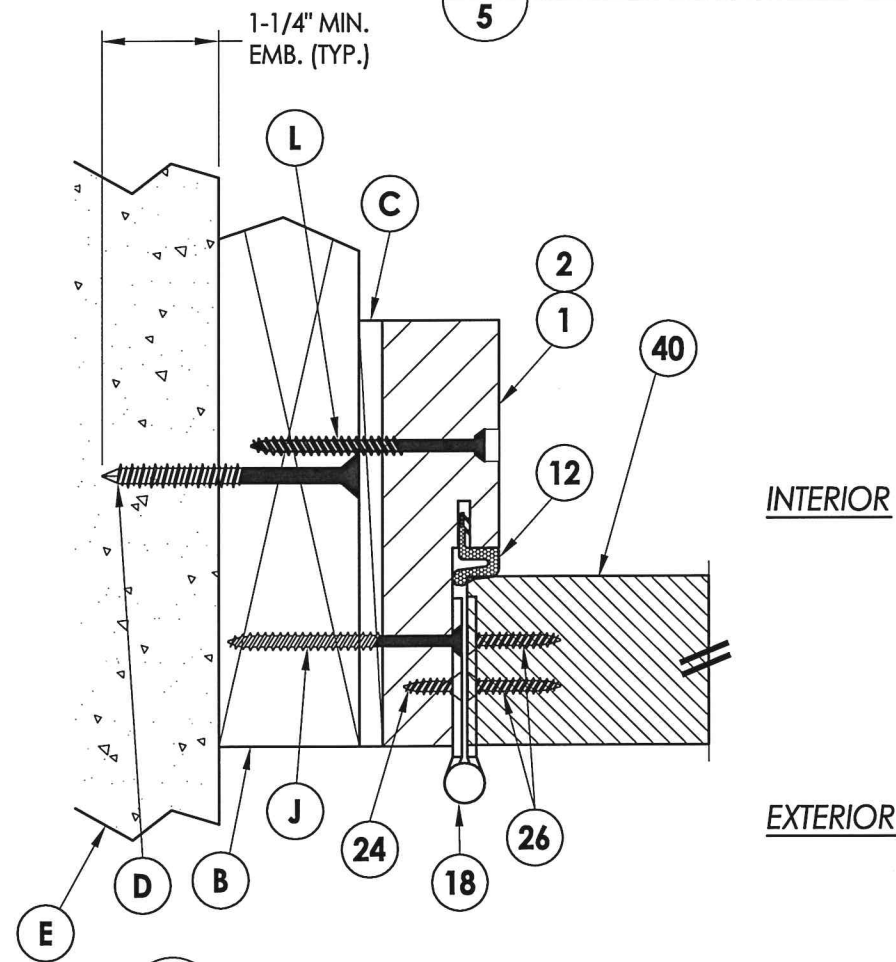

**1**  
**5** HORIZONTAL CROSS SECTION

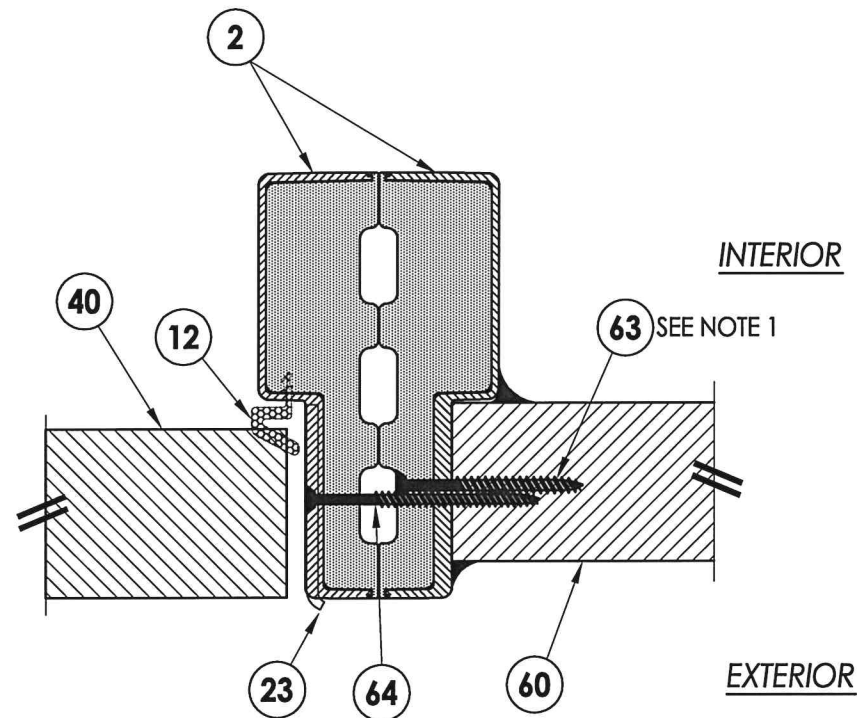

**2**  
**5** HORIZONTAL CROSS SECTION

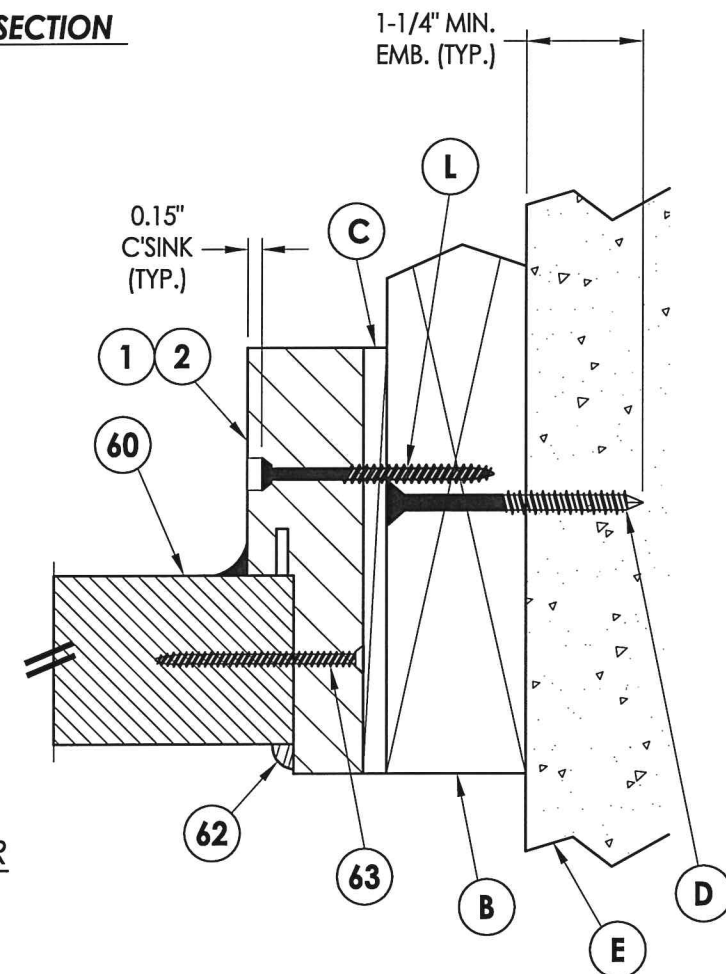

**3**  
**5** HORIZONTAL CROSS SECTION

PRODUCT:	TRINITY GLASS INT'L	
PART OR ASSEMBLY:	HORIZONTAL CROSS SECTIONS	
NO.	DATE	REVISIONS
1	03/02/15	UPDATE TO 5TH ED. (2014) FBC
JK	BY	
DATE: 02/27/12		
SCALE: N.T.S.		
DWG. BY: JK		
CHK. BY: LFS		
DRAWING NO.: FL-15255.2		
SHEET 5 OF 16		

R:\Clients\Trinity PERMANENT\Florida Product Approvals\FL-15255\C - Drawings\FL-15255\FL-15255.1-4.dwg, 6.2

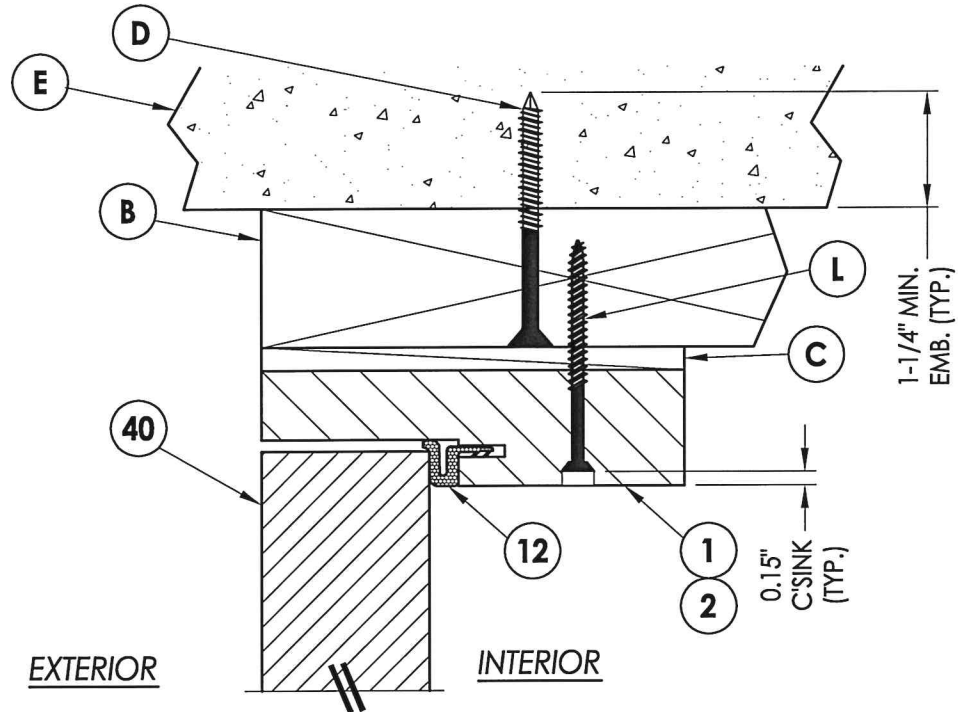

**1**  
**6** VERTICAL CROSS SECTION

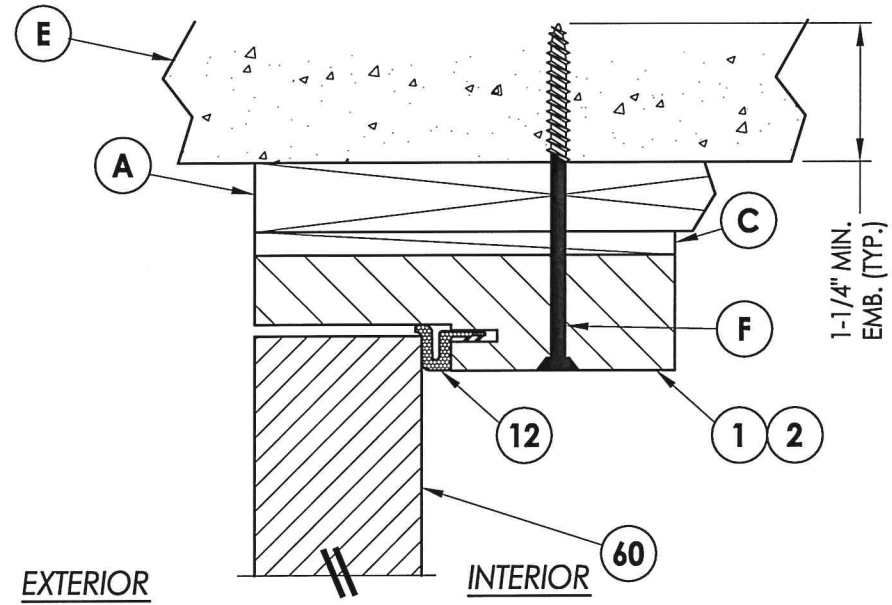

**2**  
**6** VERTICAL CROSS SECTION  
Shown w/1X sub-buck

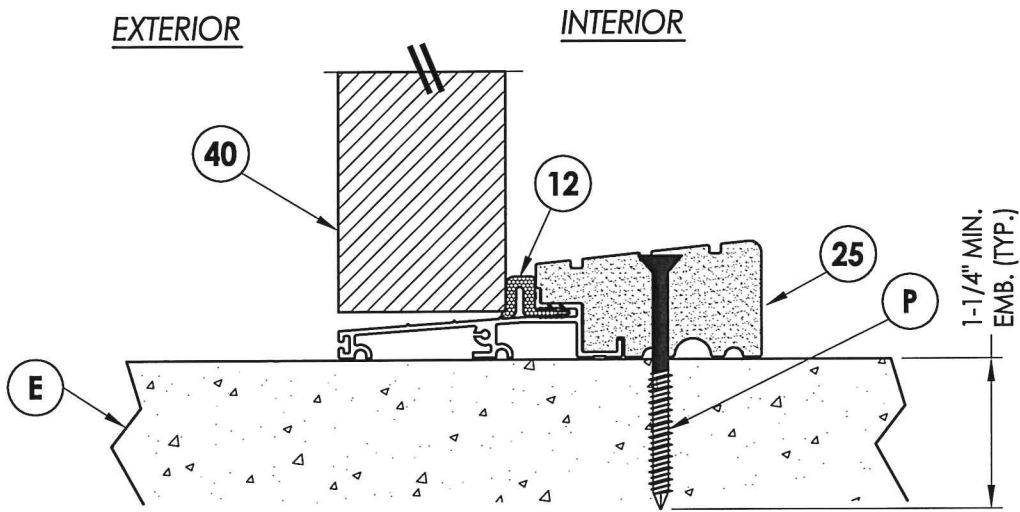

**3**  
**6** VERTICAL CROSS SECTION

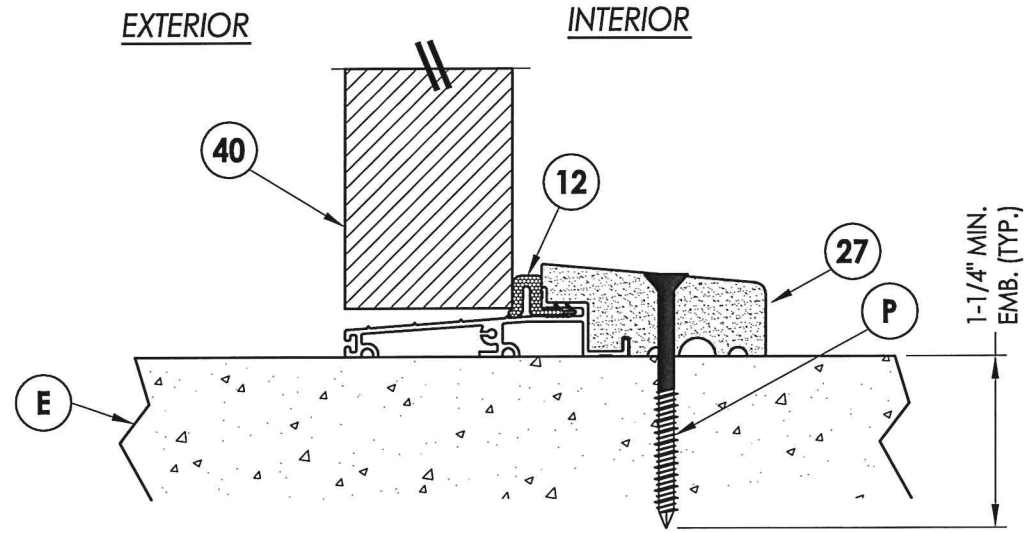

**4**  
**6** VERTICAL CROSS SECTION

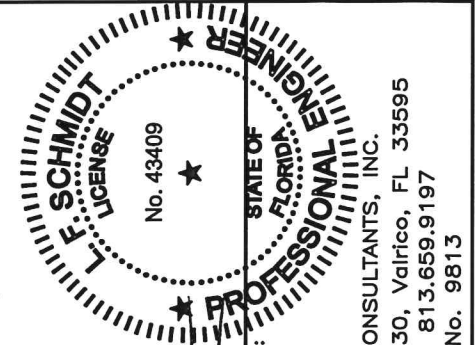

Documents Prepared By:  
Lyndon F. Schmidt  
P.E. No. 43409  
*RW* BUILDING CONSULTANTS, INC.  
P.O. Box 230, Valrico, FL 33595  
Phone No.: 813.659.9197  
FBPE C.A. No. 9813

PRODUCT:	TRINITY GLASS INT'L
PART OR ASSEMBLY:	VERTICAL CROSS SECTIONS

NO.	DATE	BY
1	03/02/15	JK
UPDATE TO 5TH ED. (2014) FBC		

DATE:	02/27/12
SCALE:	N.T.S.
DWG. BY:	JK
CHK. BY:	LFS
DRAWING NO.:	FL-15255.2
SHEET	6 OF 16

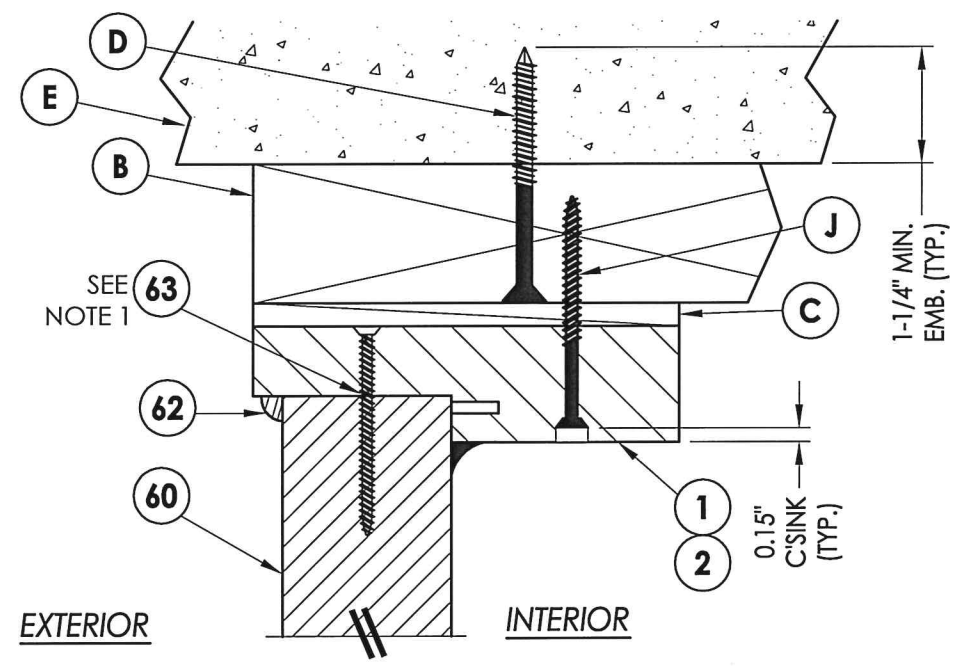

**1**  
**7** VERTICAL CROSS SECTION

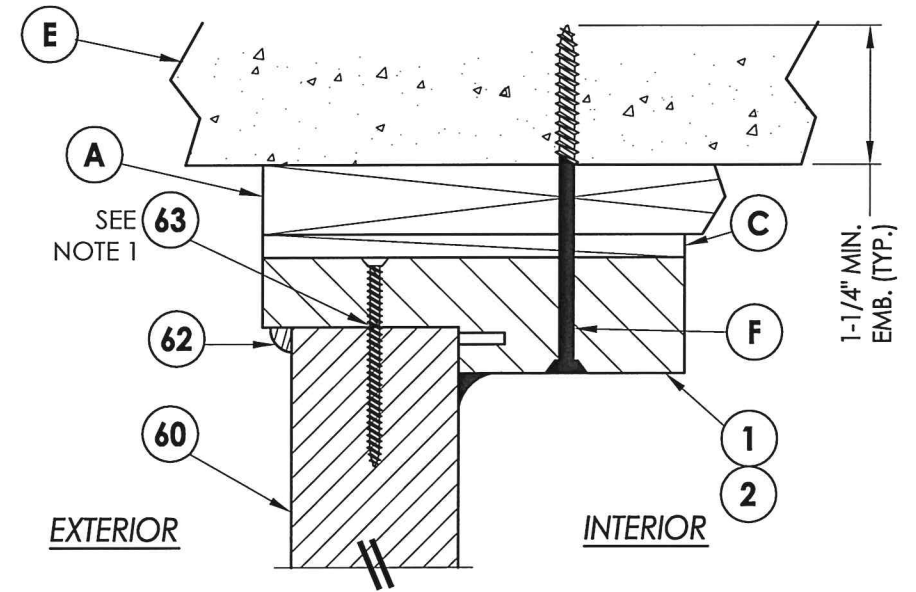

**2**  
**7** VERTICAL CROSS SECTION  
Shown w/1X sub-buck

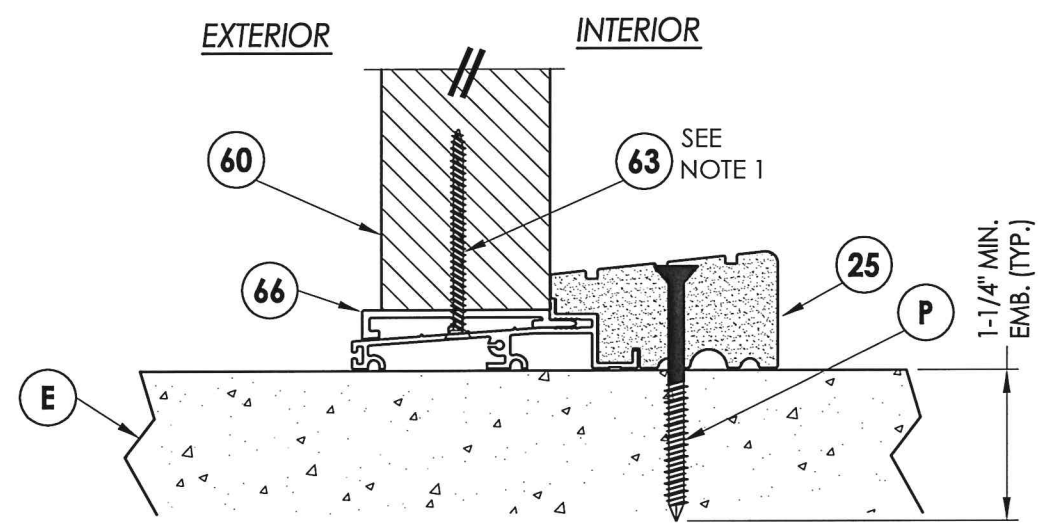

**3**  
**7** VERTICAL CROSS SECTION

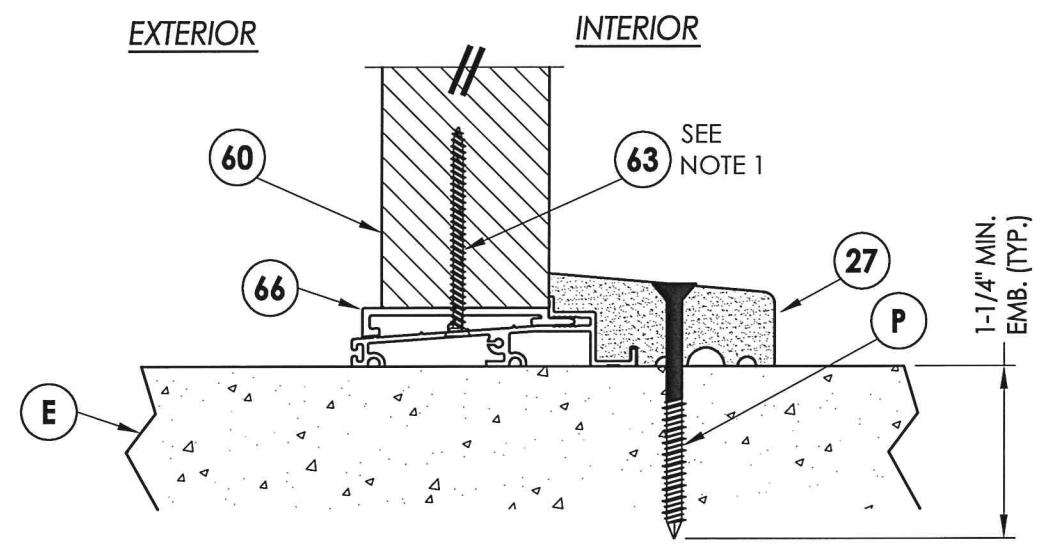

**4**  
**7** VERTICAL CROSS SECTION

NOTE:  
1. Screws thru head and sill jamb located 3" from each end and on center line.

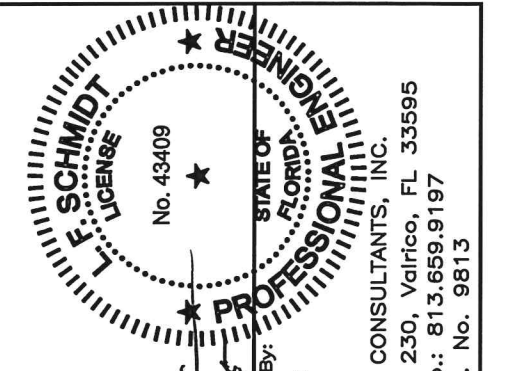

Documents Prepared By:  
Lyndon F. Schmidt  
P.E. No. 43409  
*RW*  
BUILDING CONSULTANTS, INC.  
P.O. Box 230, Vairico, FL 33595  
Phone No.: 813.659.9197  
FBPE C.A. No. 9813

PRODUCT:	TRINITY GLASS INT'L	
PART OR ASSEMBLY:	VERTICAL CROSS SECTIONS	
DATE:	02/27/12	
SCALE:	N.T.S.	
DWG. BY:	JK	
CHK. BY:	LFS	
DRAWING NO.:	FL-15255.2	
SHEET	7 of 16	
NO.	DATE	BY
1	03/02/15	JK
		FBC
		REVISIONS

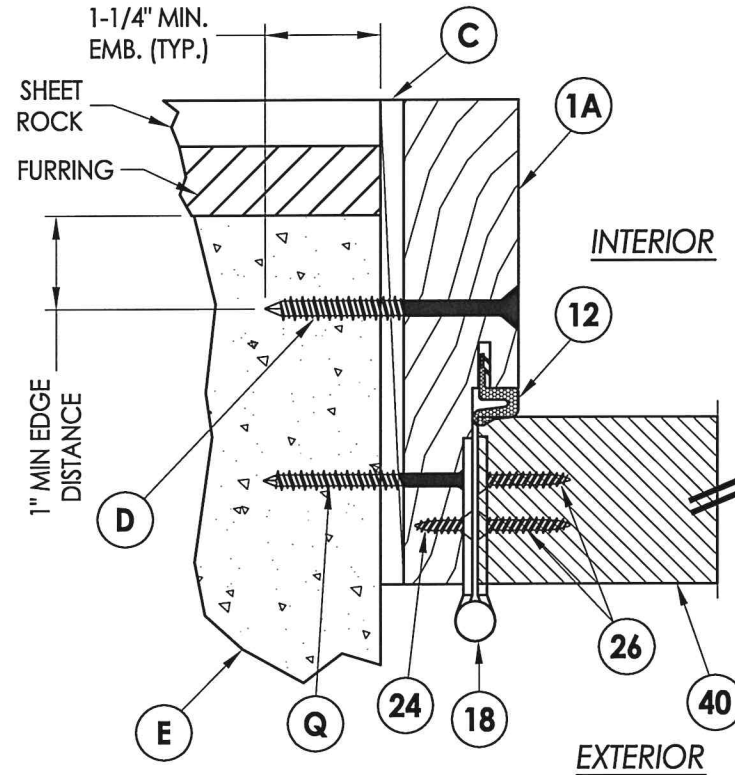
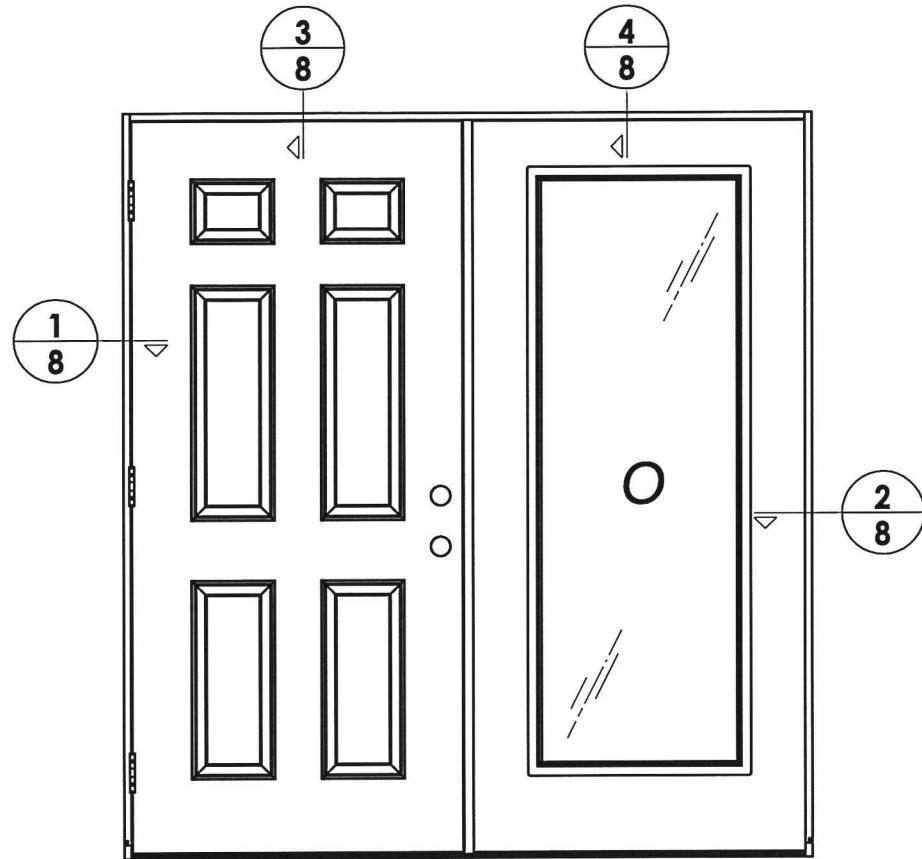

**1**  
**8** HORIZONTAL CROSS SECTION  
Direct to masonry  
(5-1/4" jamb)

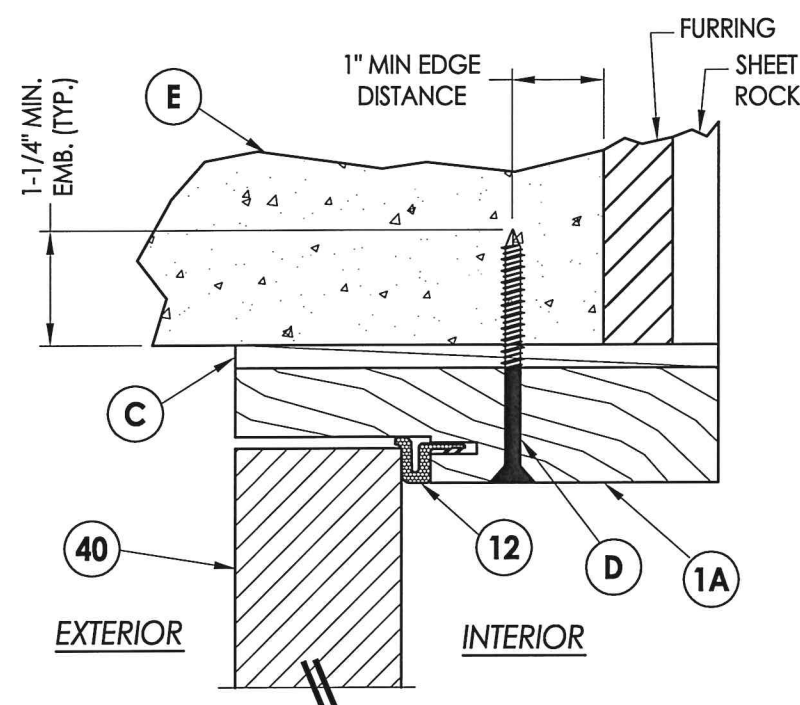

**3**  
**8** VERTICAL CROSS SECTION  
Direct to masonry  
(5-1/4" jamb)

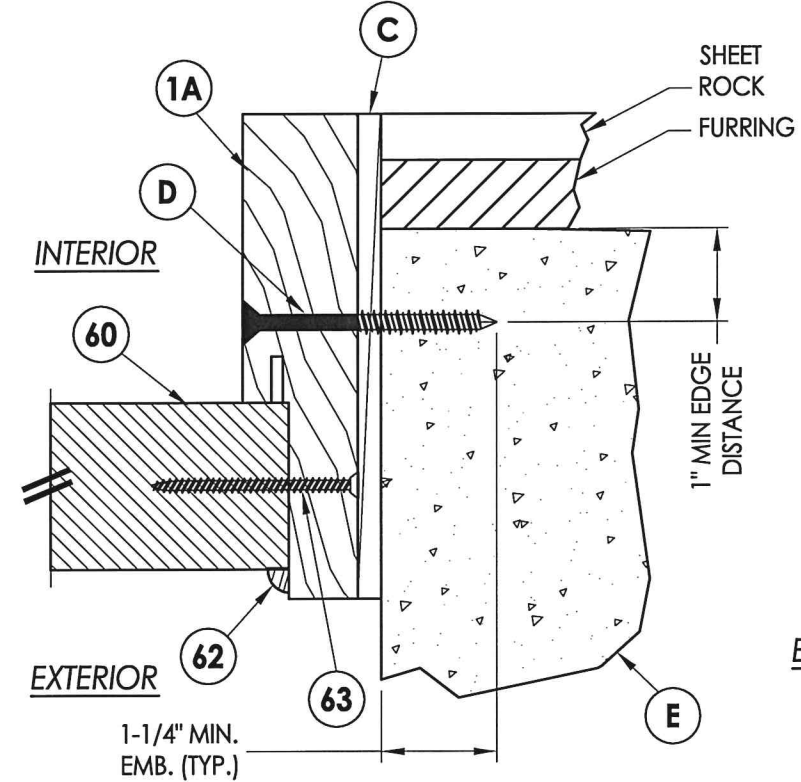
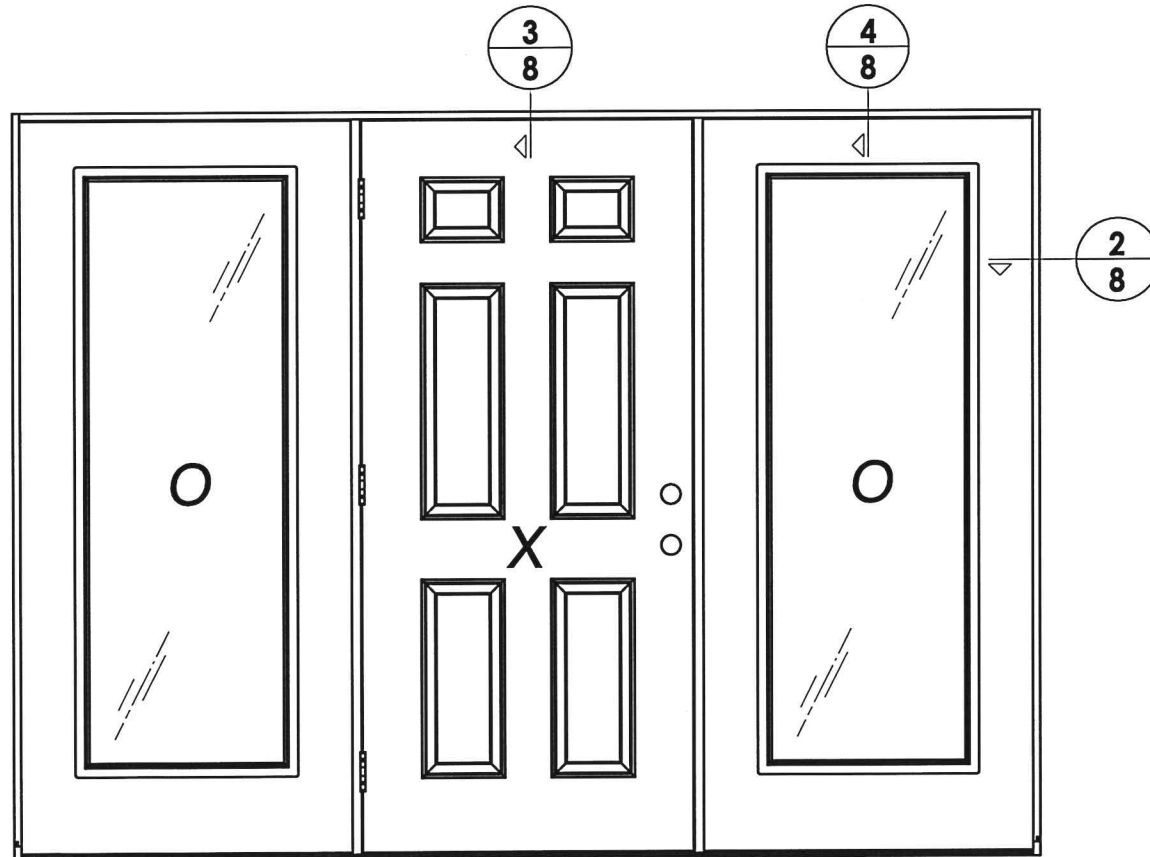

**2**  
**8** HORIZONTAL CROSS SECTION  
Direct to masonry  
(5-1/4" jamb)

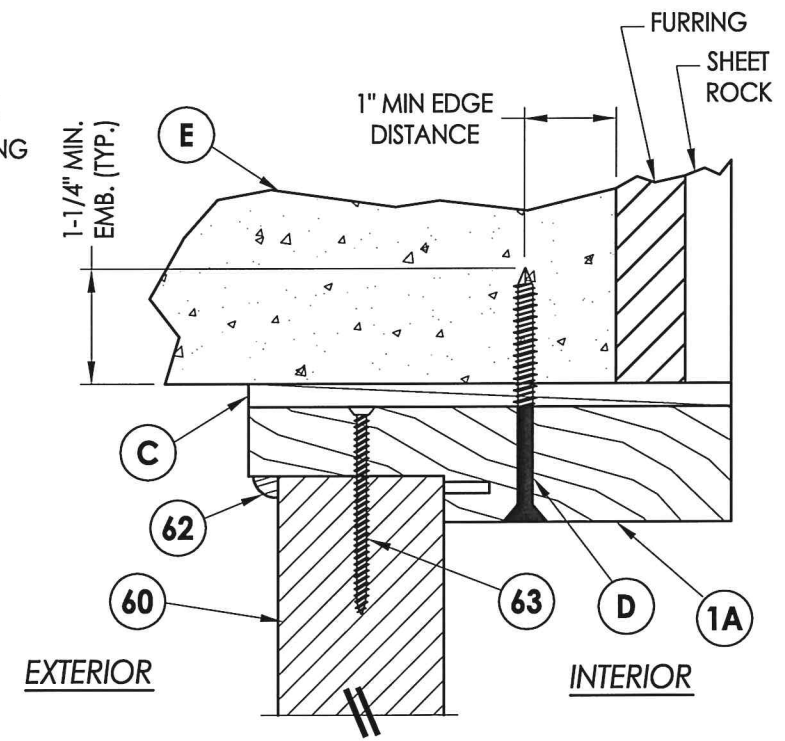

**4**  
**8** VERTICAL CROSS SECTION  
Direct to masonry  
(5-1/4" jamb)

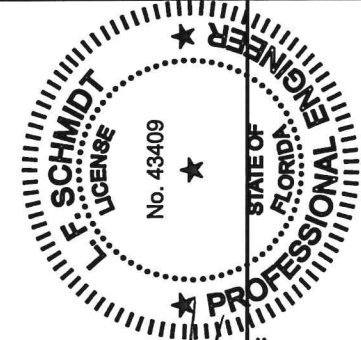

Documents Prepared By:  
Lyndon F. Schmidt  
P.E. No. 43409  
R.W. BUILDING CONSULTANTS, INC.  
P.O. Box 230, Valrico, FL 33595  
Phone No.: 813.659.9197  
FBPE C.A. No. 9813

PRODUCT: TRINITY GLASS INT'L  
PART OR ASSEMBLY: HORIZONTAL & VERTICAL CROSS SECTIONS

NO.	DATE	BY	REVISIONS
1	03/02/15	JK	UPDATE TO 5TH ED. (2014) FBC

DATE: 02/27/12  
SCALE: N.T.S.  
DWG. BY: JK  
CHK. BY: LFS  
DRAWING NO.: FL-15255.2  
SHEET 8 OF 16



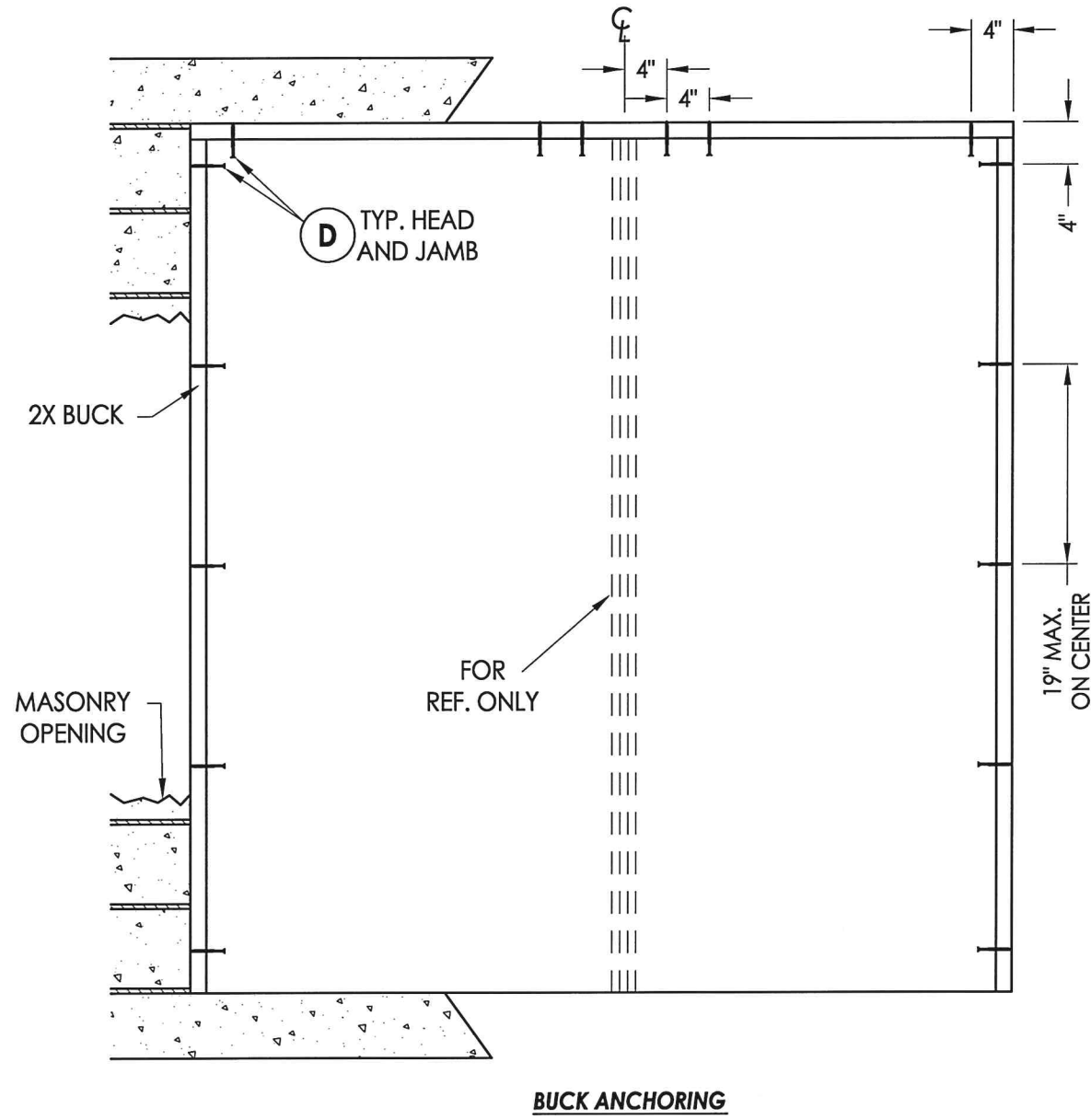

**CONCRETE ANCHOR NOTES:**

1. Concrete anchor locations at the corners may be adjusted to maintain the min. edge distance to mortar joints.
2. Concrete anchor locations noted as "MAX. ON CENTER" must be adjusted to maintain the min. edge distance to mortar joints, additional concrete anchors may be required to ensure the "MAX. ON CENTER" dimension are not exceeded.
3. Concrete anchor table:

ANCHOR TYPE	ANCHOR SIZE	MIN. EMBEDMENT	MIN. CLEARANCE TO MASONRY EDGE	MIN. CLEARANCE TO ADJACENT ANCHOR
ITW TAPCON®	1/4"	1-1/4"	2"	4"
ELCO ULTRACON®	1/4"	1-1/4"	1"	4"

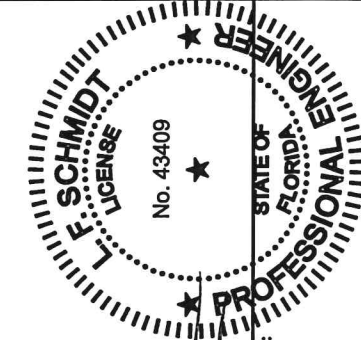

Documents Prepared By:  
 Lyndon F. Schmidt  
 P.E. No. 43409

*RW*  
 BUILDING CONSULTANTS, INC.  
 P.O. Box 230, Valrico, FL 33595  
 Phone No.: 813.659.9197  
 FBPE C.A. No. 9813

PRODUCT: TRINITY GLASS INT'L

PART OR ASSEMBLY: BUCK ANCHORING

NO.	DATE	REVISIONS
1	03/02/15	UPDATE TO 5TH ED. (2014) FBC
JK		BY

DATE: 02/27/12

SCALE: N.T.S.

DWG. BY: JK

CHK. BY: LFS

DRAWING NO.: FL-15255.2

SHEET 9 of 16

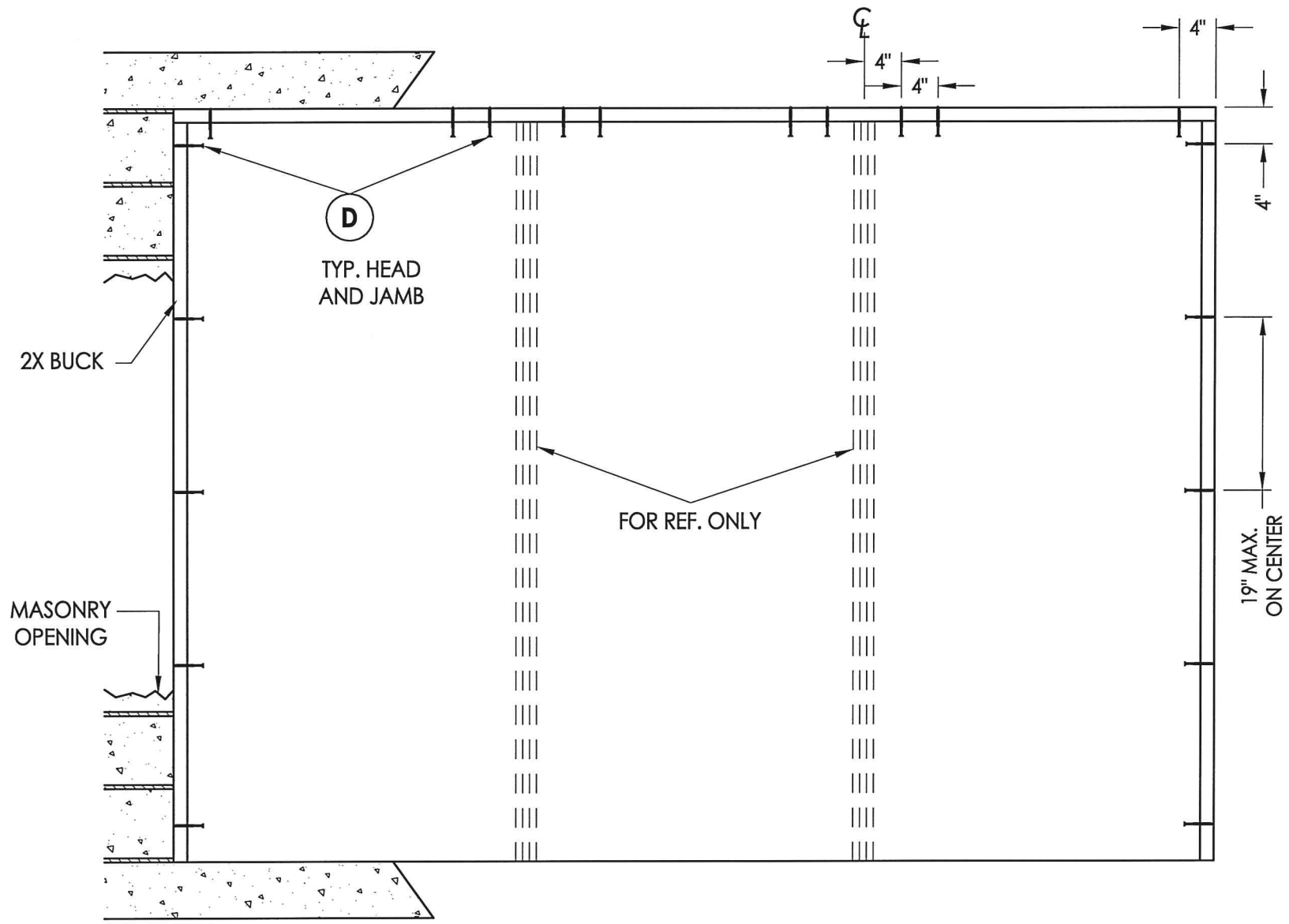

**BUCK ANCHORING**

**CONCRETE ANCHOR NOTES:**

1. Concrete anchor locations at the corners may be adjusted to maintain the min. edge distance to mortar joints.
2. Concrete anchor locations noted as "MAX. ON CENTER" must be adjusted to maintain the min. edge distance to mortar joints, additional concrete anchors may be required to ensure the "MAX. ON CENTER" dimension are not exceeded.
3. Concrete anchor table:

ANCHOR TYPE	ANCHOR SIZE	MIN. EMBEDMENT	MIN. CLEARANCE TO MASONRY EDGE	MIN. CLEARANCE TO ADJACENT ANCHOR
ITW TAPCON®	1/4"	1-1/4"	2"	4"
ELCO ULTRACON®	1/4"	1-1/4"	1"	4"

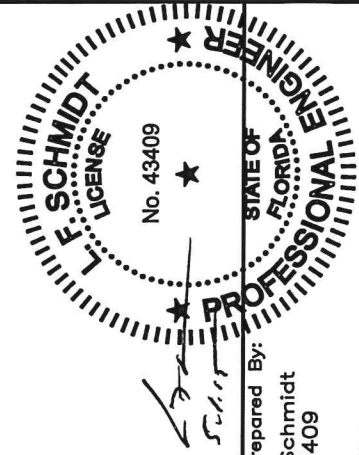

Documents Prepared By:  
Lyndon F. Schmidt  
P.E. No. 43409

**RW** BUILDING CONSULTANTS, INC.  
P.O. Box 230, Valrico, FL 33595  
Phone No.: 813.659.9197  
FBPE C.A. No. 9813

PRODUCT:	TRINITY GLASS INT'L	
PART OR ASSEMBLY:	BUCK ANCHORING	
DATE:	02/27/12	
SCALE:	N.T.S.	
DWG. BY:	JK	
CHK. BY:	LFS	
DRAWING NO.:	FL-15255.2	
SHEET	10 OF 16	
NO.	DATE	REVISIONS
1	03/02/15	UPDATE TO 5TH ED. (2014) FBC
JK		BY

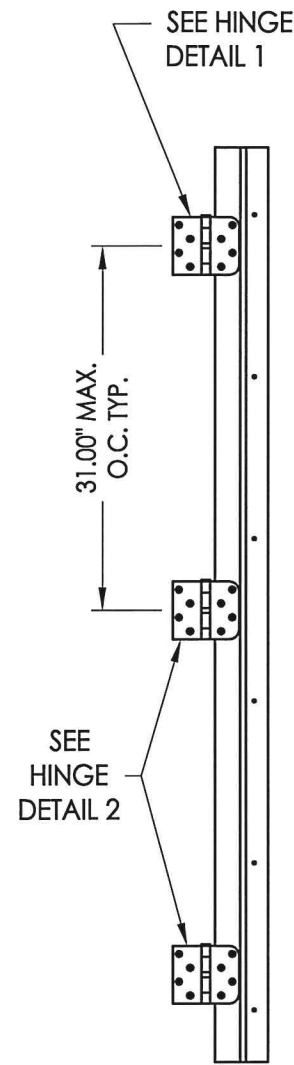

**HINGE JAMB**

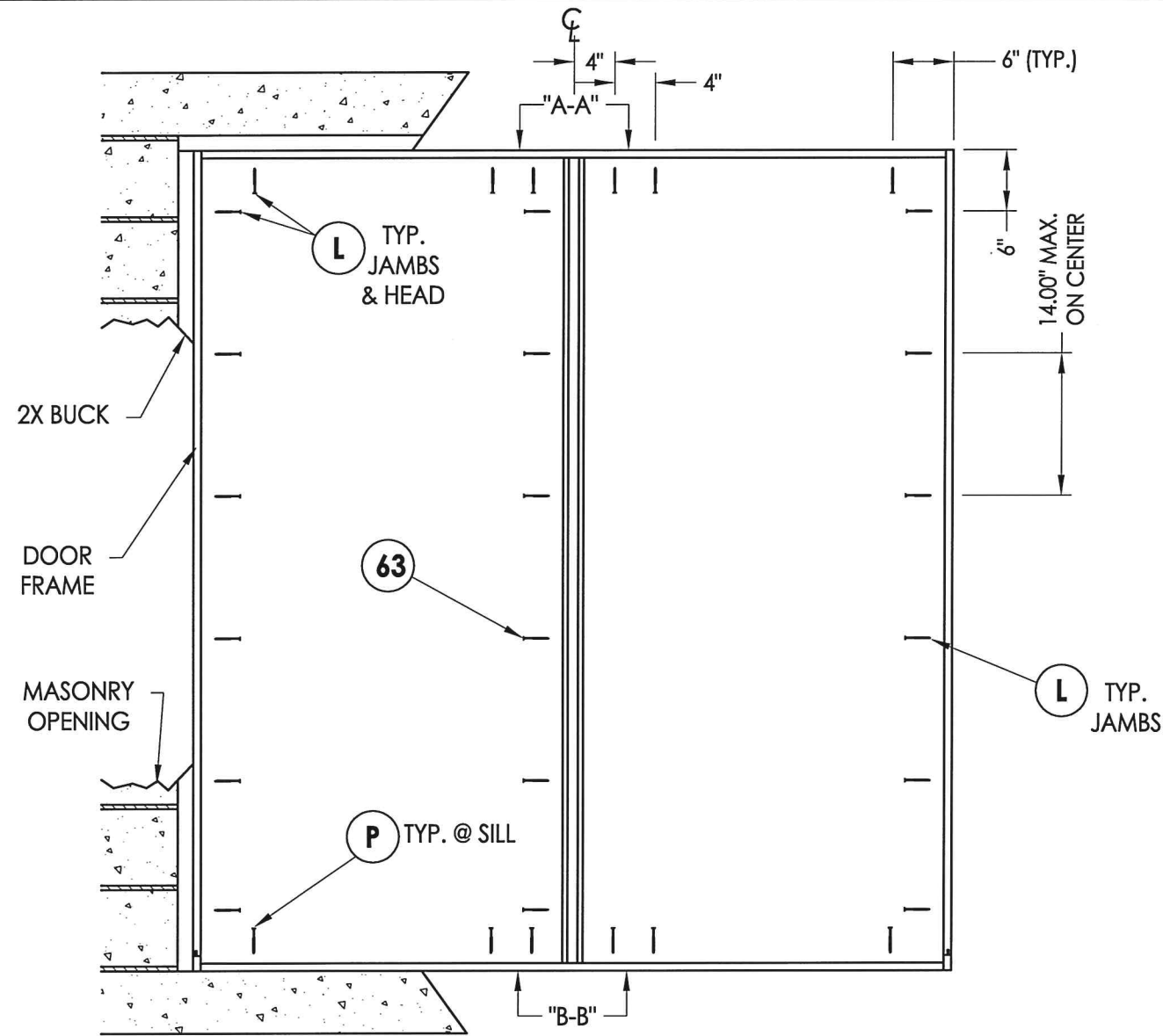

**FRAME ANCHORING**  
Masonry 2X buck construction

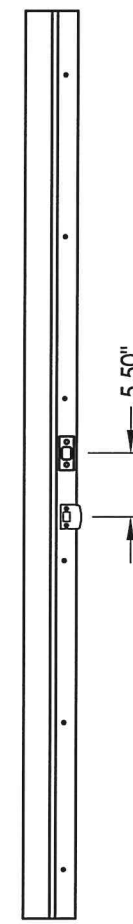

**STRIKE JAMB**

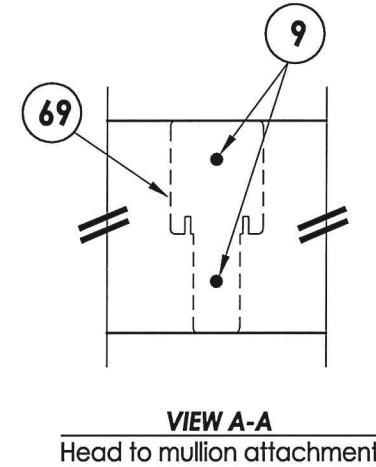

**VIEW A-A**  
Head to mullion attachment

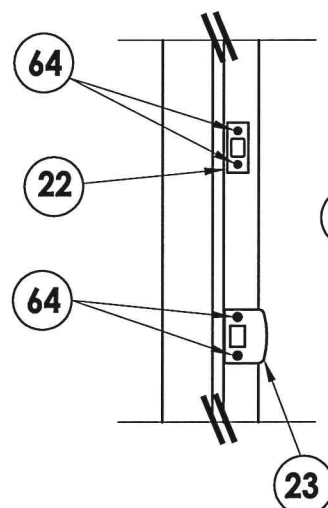

**STRIKE PLATE DETAIL**

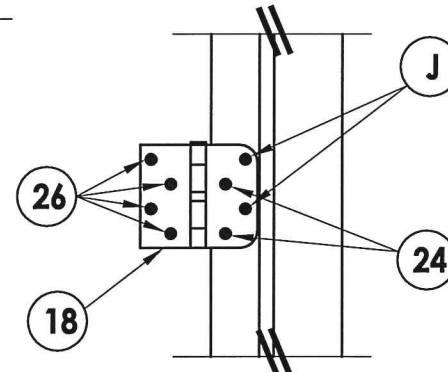

**HINGE DETAIL 1**

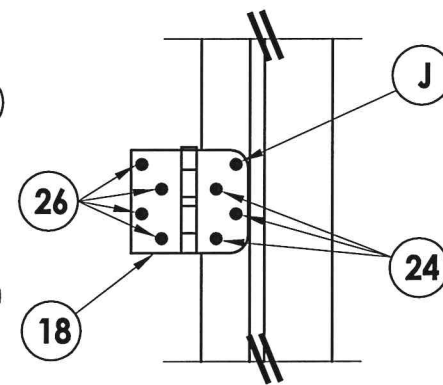

**HINGE DETAIL 2**

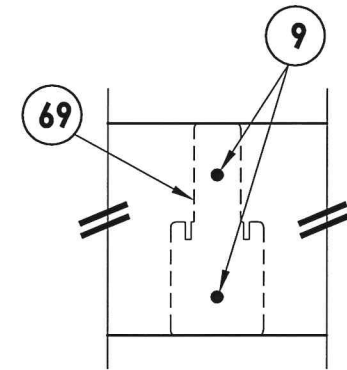

**VIEW B-B**  
Sill to mullion attachment

**CONCRETE ANCHOR NOTES:**

1. Concrete anchor locations at the corners may be adjusted to maintain the min. edge distance to mortar joints.
2. Concrete anchor locations noted as "MAX. ON CENTER" must be adjusted to maintain the min. edge distance to mortar joints, additional concrete anchors may be required to ensure the "MAX. ON CENTER" dimension are not exceeded.
3. Concrete anchor table:

ANCHOR TYPE	ANCHOR SIZE	MIN. EMBEDMENT	MIN. CLEARANCE TO MASONRY EDGE	MIN. CLEARANCE TO ADJACENT ANCHOR
ITW TAPCON®	1/4"	1-1/4"	2"	4"
ELCO ULTRACON®	1/4"	1-1/4"	1"	4"

**WOOD SCREW INSTALLATION NOTES:**

1. Maintain a minimum 5/8" edge distance, 1" end distance, & 1" o.c. spacing of wood screws to prevent the splitting of wood.

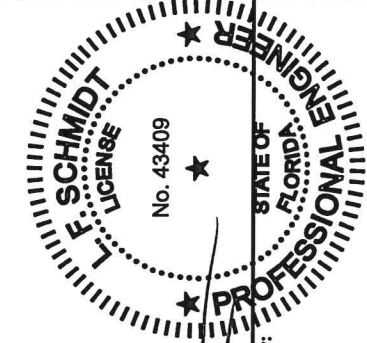

Documents Prepared By:  
Lyndon F. Schmidt  
P.E. No. 43409

**R.W.** BUILDING CONSULTANTS, INC.  
P.O. Box 230, Vairco, FL 33595  
Phone No.: 813.659.9197  
FBPE C.A. No. 9813

PRODUCT: TRINITY GLASS INT'L  
PART OR ASSEMBLY: FRAME ANCHORING  
2X BUCK MASONRY CONSTRUCTION

NO.	DATE	REVISIONS
1	03/02/15	UPDATE TO 5TH ED. (2014) FBC

DATE: 02/27/12  
SCALE: N.T.S.  
DWG. BY: JK  
CHK. BY: LFS  
DRAWING NO.: FL-15255.2  
SHEET 11 OF 16

R:\Clients\Trinity PERMANENT\Florida Product Approvals\FL-15255\C - Drawings\FL-15255\FL-15255.1-4.dwg, 12.2

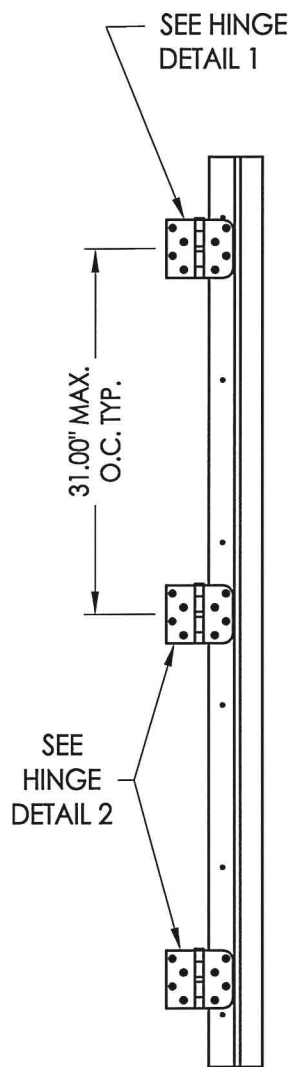

**HINGE JAMB**

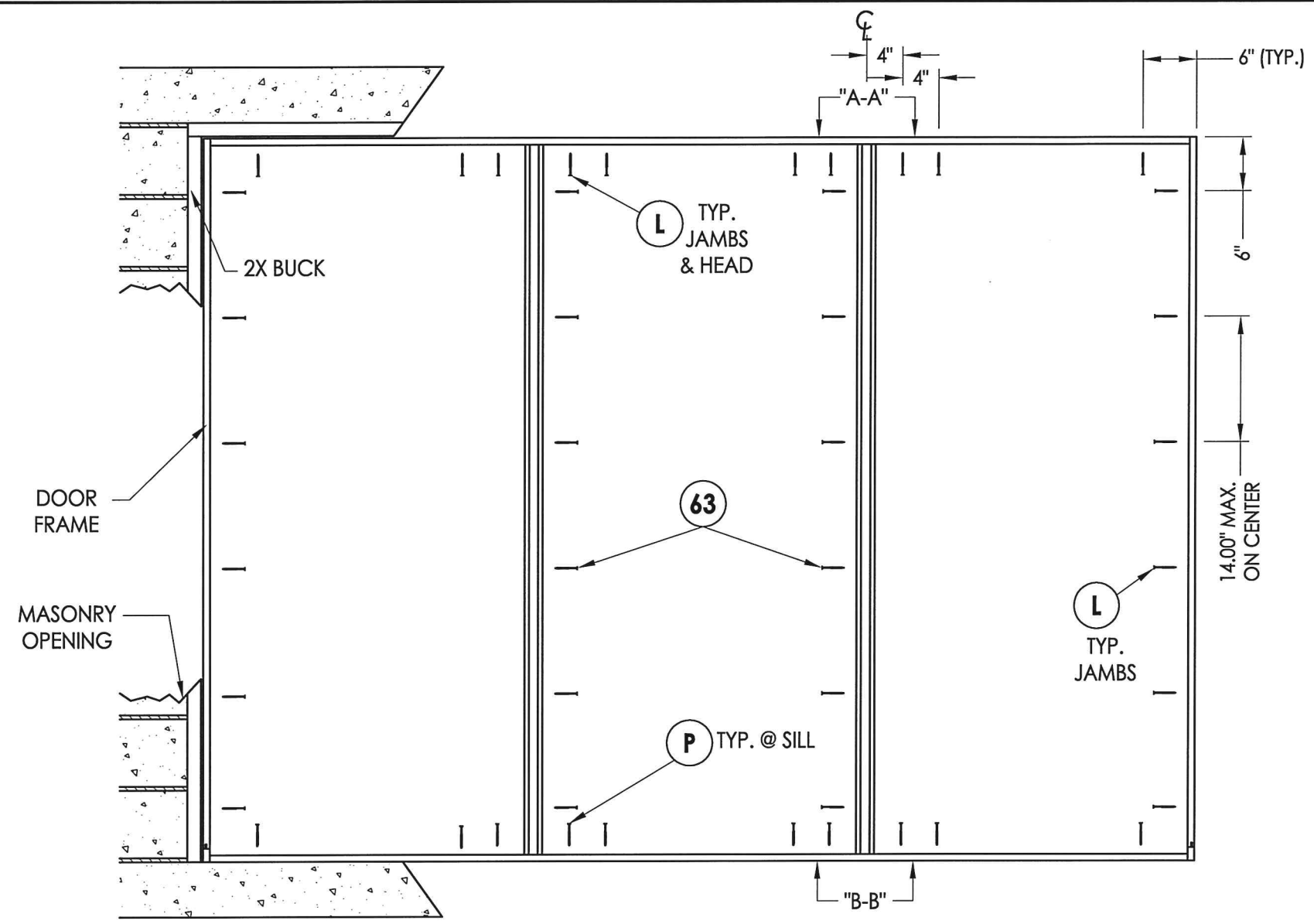

**FRAME ANCHORING**  
Masonry 2X buck construction

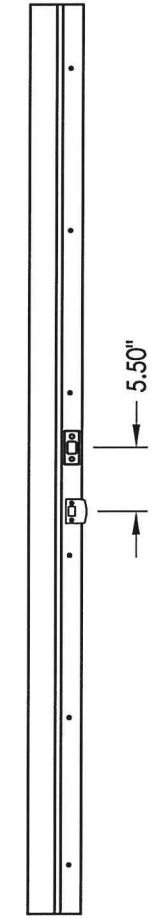

**STRIKE JAMB**

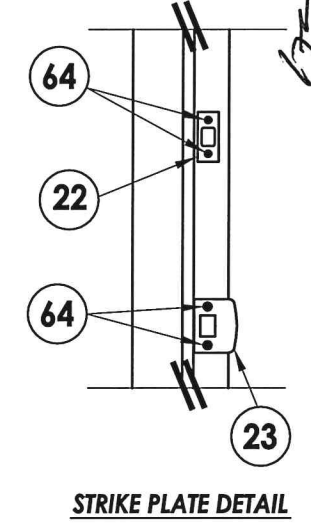

**STRIKE PLATE DETAIL**

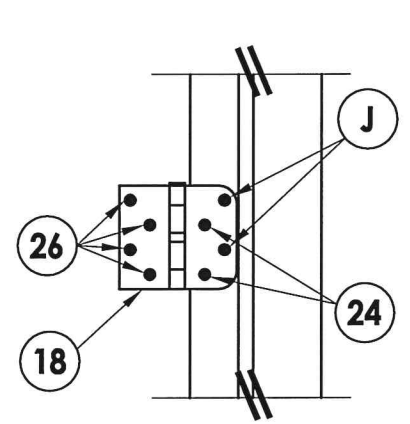

**HINGE DETAIL 1**

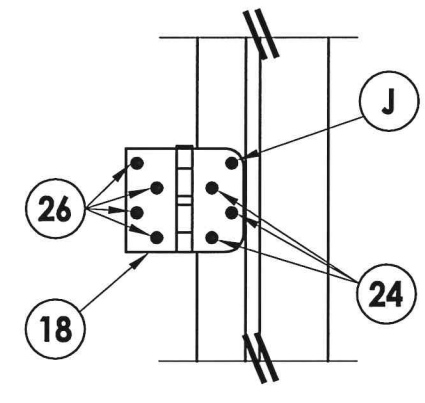

**HINGE DETAIL 2**

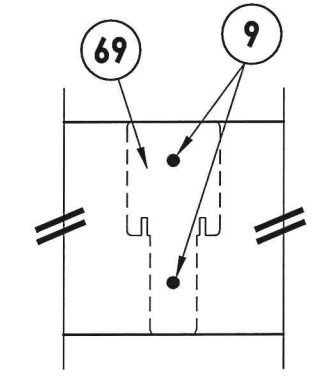

**VIEW A-A**  
Head to mullion attachment

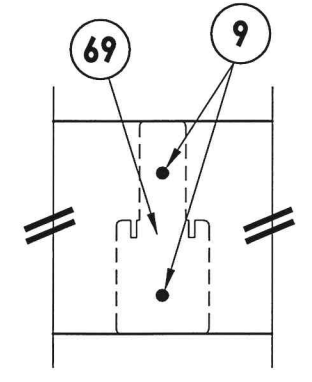

**VIEW B-B**  
Sill to mullion attachment

**CONCRETE ANCHOR NOTES:**

1. Concrete anchor locations at the corners may be adjusted to maintain the min. edge distance to mortar joints.
2. Concrete anchor locations noted as "MAX. ON CENTER" must be adjusted to maintain the min. edge distance to mortar joints, additional concrete anchors may be required to ensure the "MAX. ON CENTER" dimension are not exceeded.
3. Concrete anchor table:

ANCHOR TYPE	ANCHOR SIZE	MIN. EMBEDMENT	MIN. CLEARANCE TO MASONRY EDGE	MIN. CLEARANCE TO ADJACENT ANCHOR
ITW TAPCON®	1/4"	1-1/4"	2"	4"
ELCO ULTRACON®	1/4"	1-1/4"	1"	4"

**WOOD SCREW INSTALLATION NOTES:**

1. Maintain a minimum 5/8" edge distance, 1" end distance, & 1" o.c. spacing of wood screws to prevent the splitting of wood.

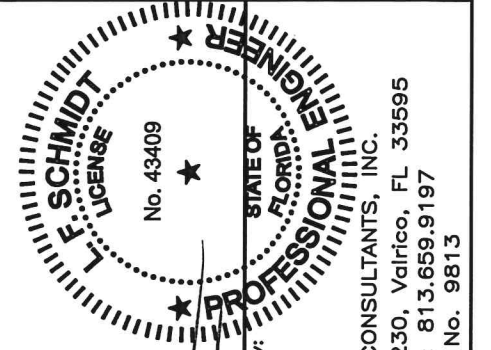

Documents Prepared By:  
Lyndon F. Schmidt  
P.E. No. 43409

**RW** BUILDING CONSULTANTS, INC.  
P.O. Box 230, Valrico, FL 33595  
Phone No.: 813.659.9197  
FBPE C.A. No. 9813

PRODUCT: TRINITY GLASS INT'L

PART OR ASSEMBLY:  
FRAME ANCHORING  
2X BUCK MASONRY CONSTRUCTION

NO.	DATE	REVISIONS
1	03/02/15	UPDATE TO 5TH ED. (2014) FBC

DATE: 02/27/12  
SCALE: N.T.S.  
DWG. BY: JK  
CHK. BY: LFS  
DRAWING NO.: FL-15255.2  
SHEET 12 OF 16

R:\Clients\Trinity PERMANENT\Florida Product Approvals\FL-15255\C - Drawings\FL-15255\1-4.dwg, 13.2

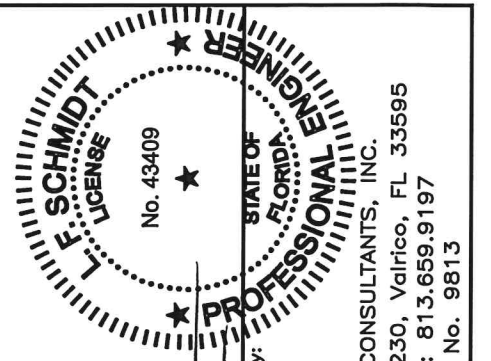
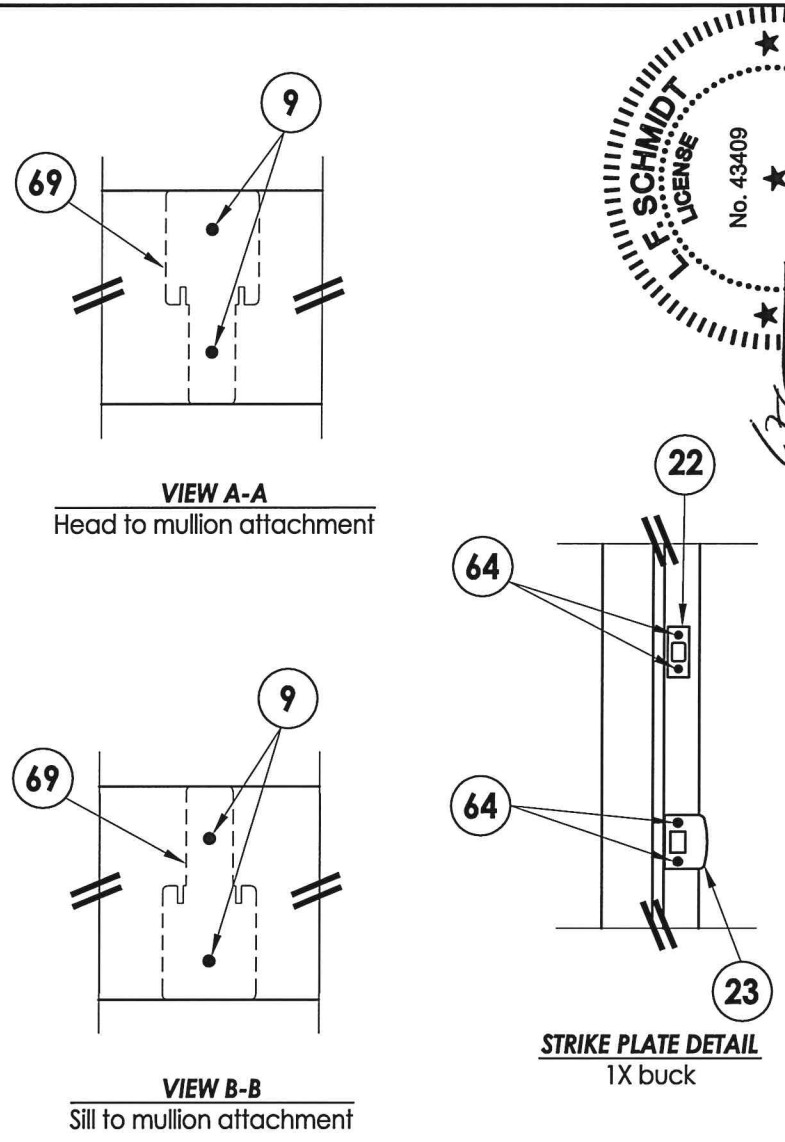
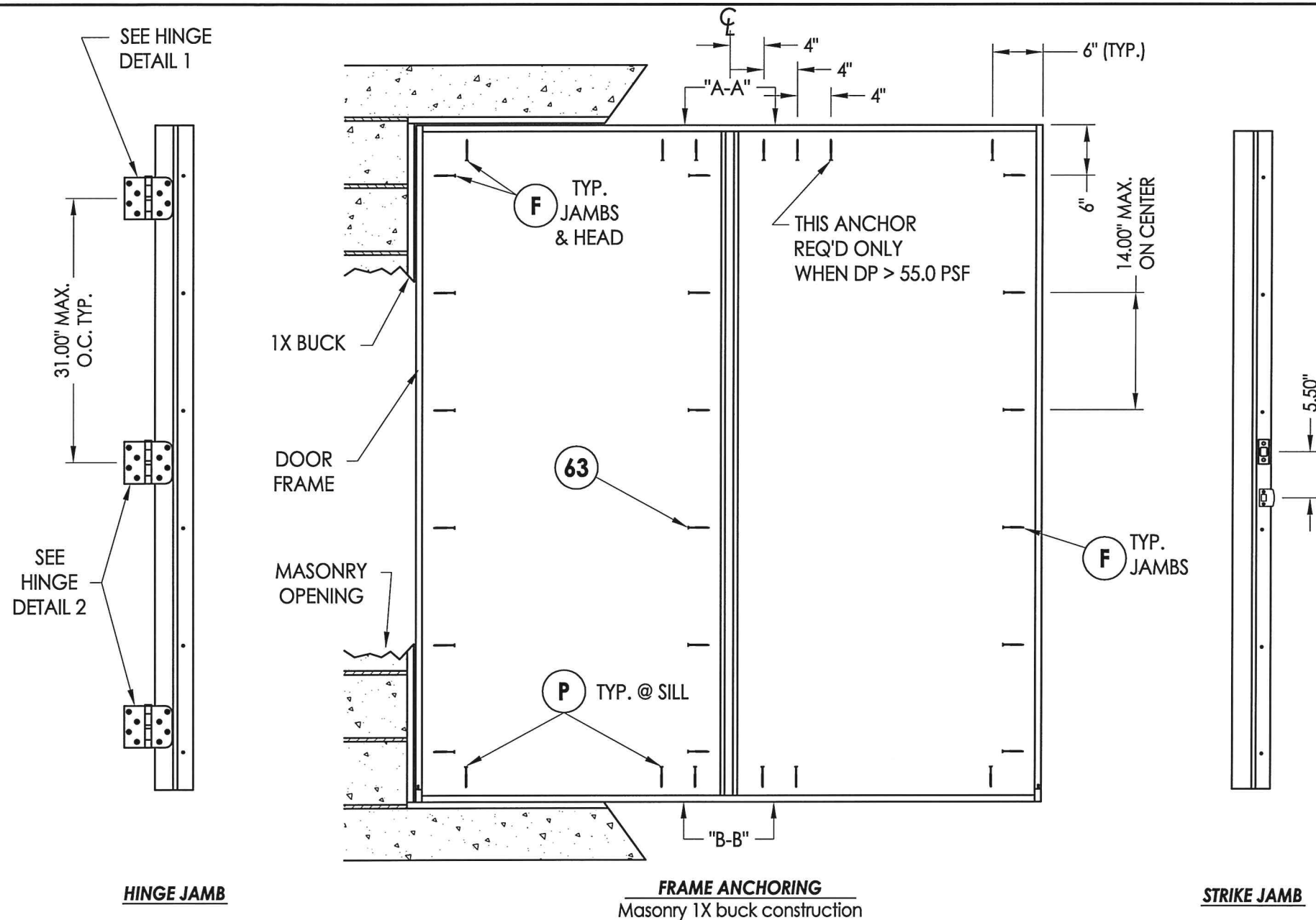

Documents Prepared By:  
Lyndon F. Schmidt  
P.E. No. 43409

RW BUILDING CONSULTANTS, INC.  
P.O. Box 230, Valrico, FL 33595  
Phone No.: 813.659.9197  
FBPE C.A. No. 9813

PRODUCT: TRINITY GLASS INT'L

PART OR ASSEMBLY:  
FRAME ANCHORING  
1x BUCK MASONRY CONSTRUCTION

NO.	DATE	BY	REVISIONS
1	03/02/15	JK	UPDATE TO 5TH ED. (2014) FBC

DATE: 02/27/12  
SCALE: N.T.S.  
DWG. BY: JK  
CHK. BY: LFS  
DRAWING NO.: FL-15255.2  
SHEET 13 OF 16

**CONCRETE ANCHOR NOTES:**

- Concrete anchor locations at the corners may be adjusted to maintain the min. edge distance to mortar joints.
- Concrete anchor locations noted as "MAX. ON CENTER" must be adjusted to maintain the min. edge distance to mortar joints, additional concrete anchors may be required to ensure the "MAX. ON CENTER" dimension are not exceeded.
- Concrete anchor table:

ANCHOR TYPE	ANCHOR SIZE	MIN. EMBEDMENT	MIN. CLEARANCE TO MASONRY EDGE	MIN. CLEARANCE TO ADJACENT ANCHOR
ITW TAPCON®	1/4"	1-1/4"	2"	4"
ELCO ULTRACON®	1/4"	1-1/4"	1"	4"
ITW TAPCON®	3/16"	1-1/4"	3"	1-1/2"

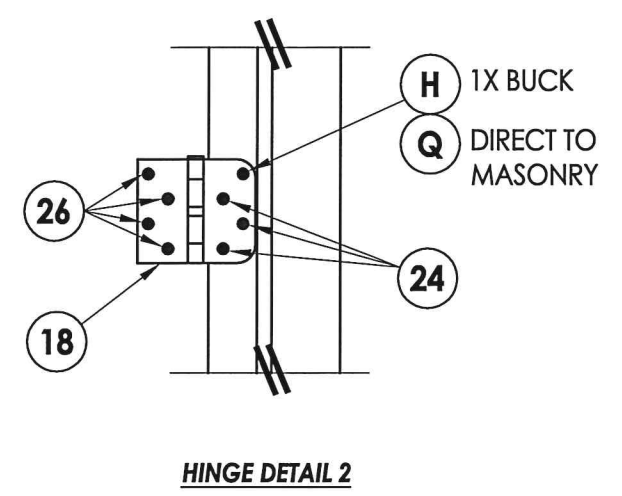
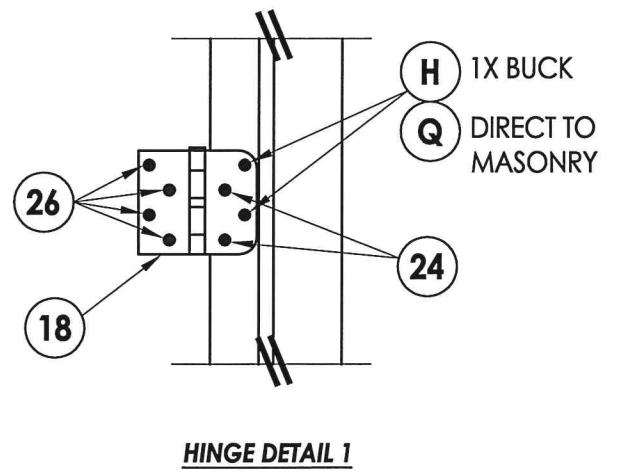

R:\Clients\Trinity PERMANENT\Florida Product Approvals\FL-15255\C - Drawings\FL-15255\1-4.dwg, 14.2

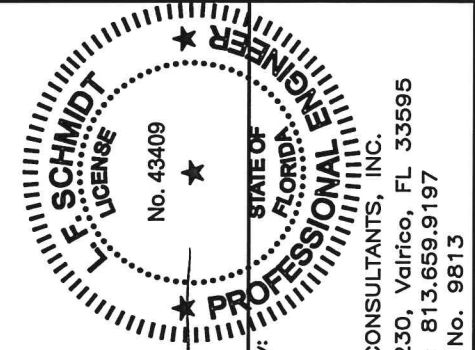
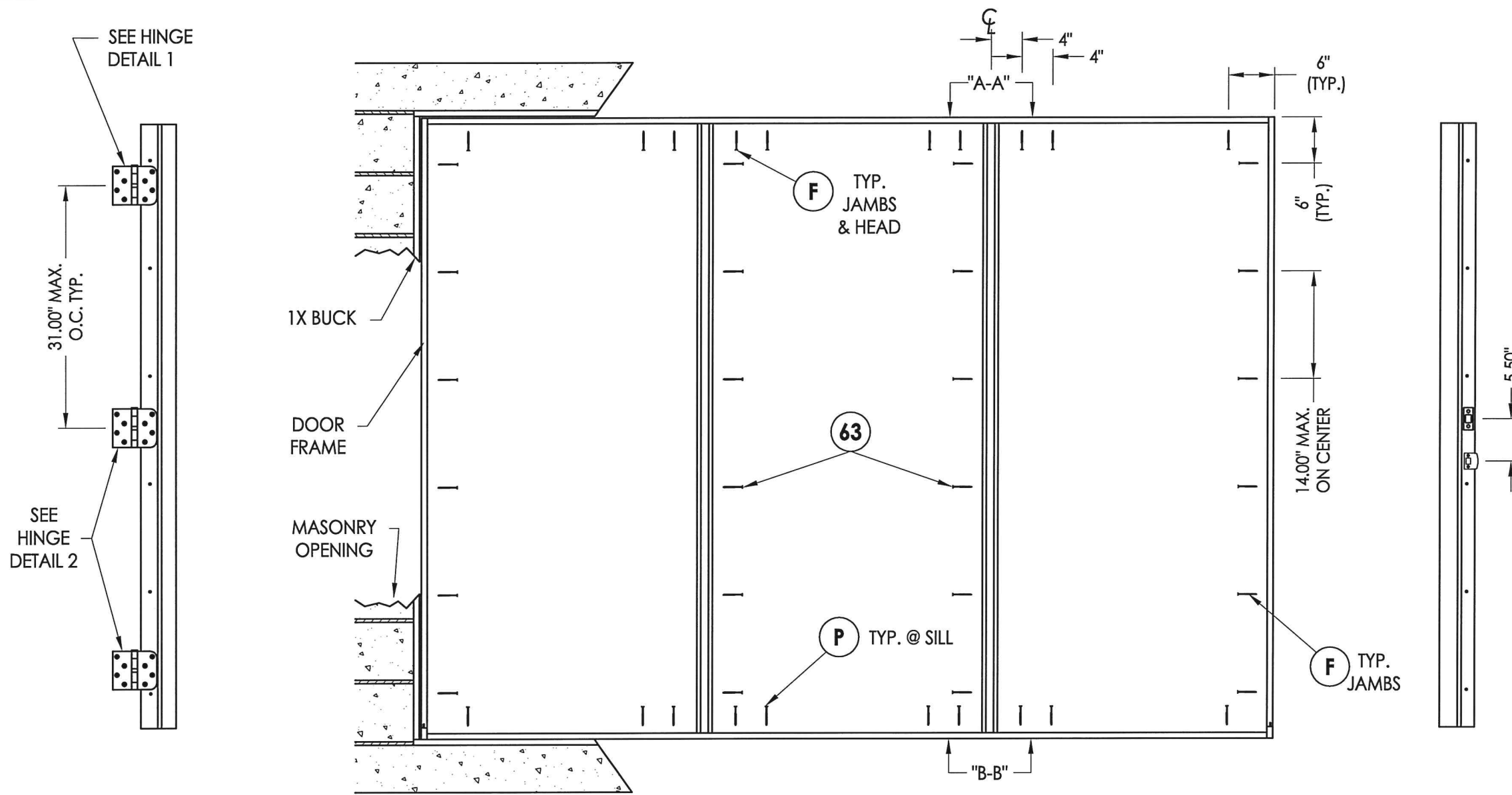

Documents Prepared By:  
Lyndon F. Schmidt  
P.E. No. 43409

**R.W.** BUILDING CONSULTANTS, INC.  
P.O. Box 230, Valrico, FL 33595  
Phone No.: 813.659.9197  
FBPE C.A. No. 9813

**HINGE JAMB**

**FRAME ANCHORING**  
Masonry 1X buck construction

**STRIKE JAMB**

**STRIKE PLATE DETAIL**  
1X buck

**CONCRETE ANCHOR NOTES:**

- Concrete anchor locations at the corners may be adjusted to maintain the min. edge distance to mortar joints.
- Concrete anchor locations noted as "MAX. ON CENTER" must be adjusted to maintain the min. edge distance to mortar joints, additional concrete anchors may be required to ensure the "MAX. ON CENTER" dimension are not exceeded.
- Concrete anchor table:

ANCHOR TYPE	ANCHOR SIZE	MIN. EMBEDMENT	MIN. CLEARANCE TO MASONRY EDGE	MIN. CLEARANCE TO ADJACENT ANCHOR
ITW TAPCON®	1/4"	1-1/4"	2"	4"
ELCO ULTRACON®	1/4"	1-1/4"	1"	4"
ITW TAPCON®	3/16"	1-1/4"	3"	1-1/2"

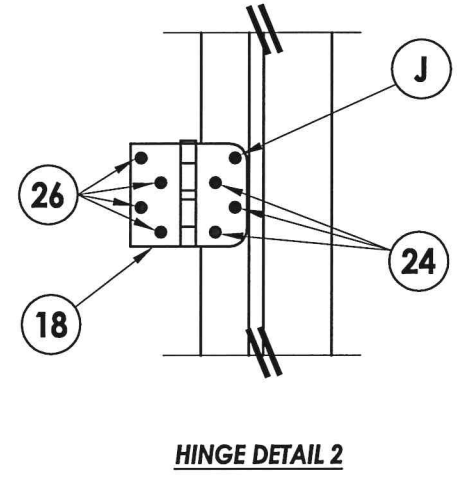
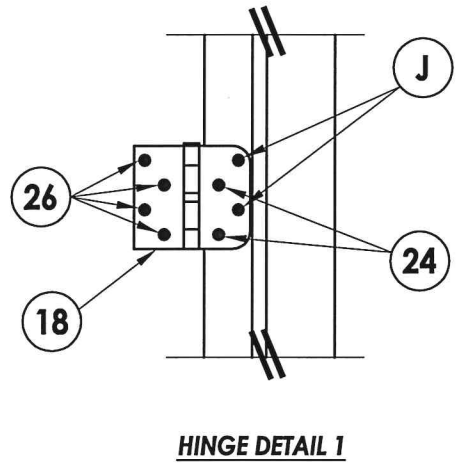
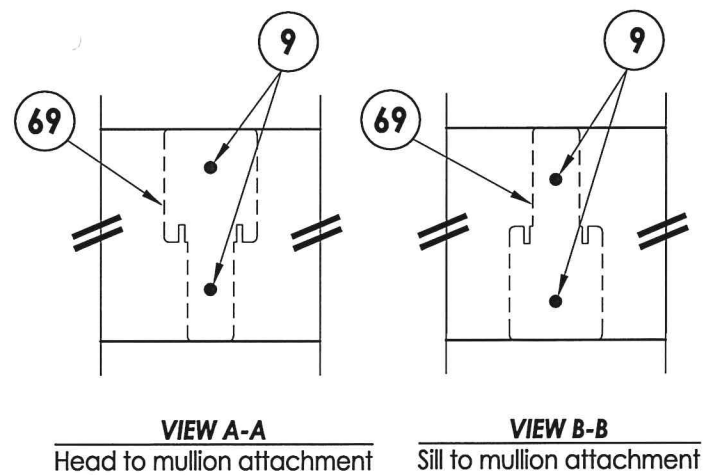

PRODUCT: TRINITY GLASS INT'L

PART OR ASSEMBLY: FRAME ANCHORING  
1x BUCK MASONRY CONSTRUCTION

NO.	DATE	BY	REVISIONS
1	03/02/15	JK	UPDATE TO 5TH ED. (2014) FBC

DATE: 02/27/12  
SCALE: N.T.S.  
DWG. BY: JK  
CHK. BY: LFS  
DRAWING NO.: FL-15255.2  
SHEET 14 OF 16

R:\Clients\Trinity PERMANENT\Florida Product Approvals\FL-15255\C - Drawings\FL-15255\FL-15255.1-4.dwg, 15.2

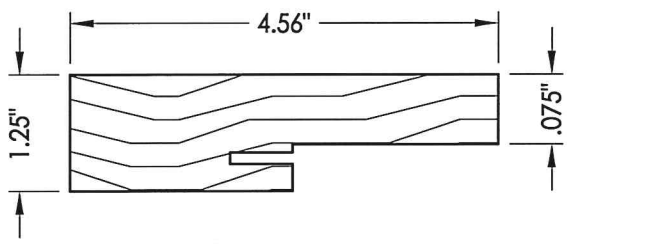

**1 SIDE & HEAD JAMBS**

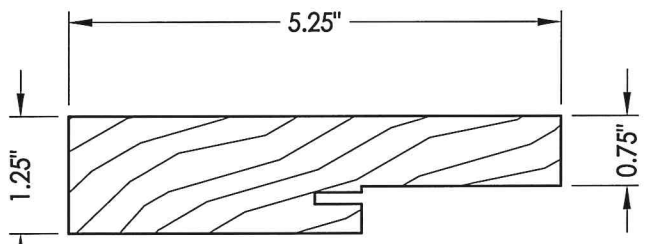

**1A SIDE & HEAD JAMBS**  
(5-1/4" or larger)

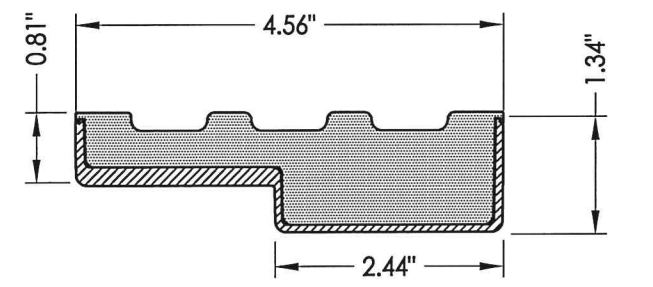

**2 HEAD AND JAMBS**  
Composite PVC Base  
w/ Fiberglass Wrap

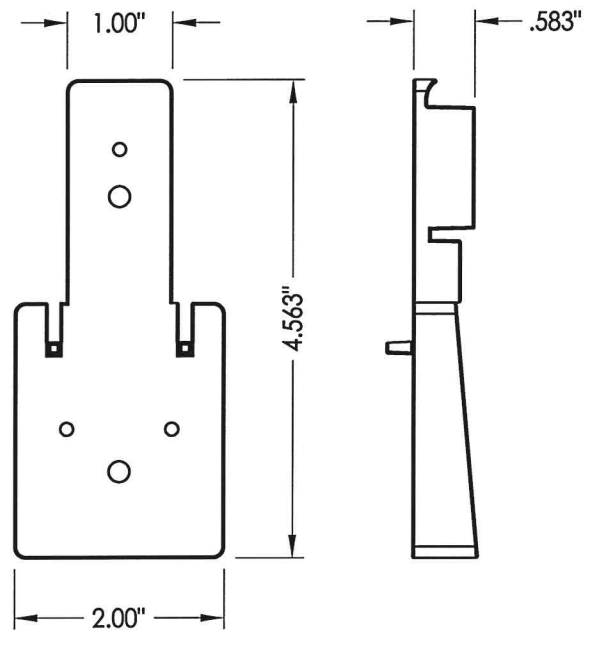

**69 MULLION BASE KIT**  
Optional

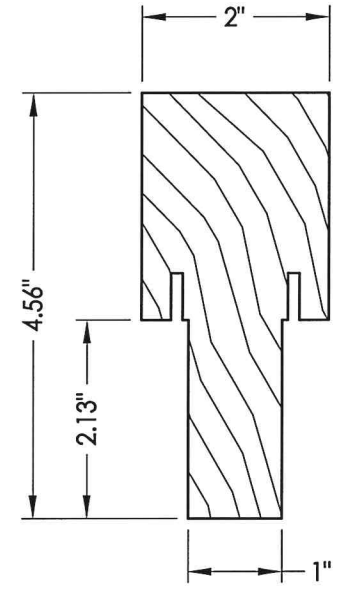

**67 INTEGRAL MULLION**

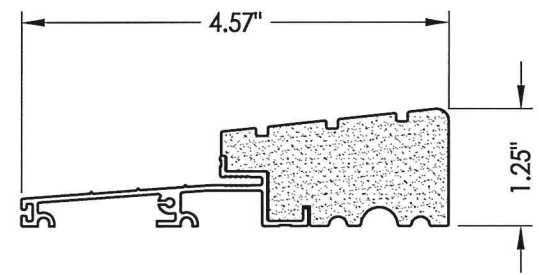

**25 OUTSWING THRESHOLD**  
High-dam option

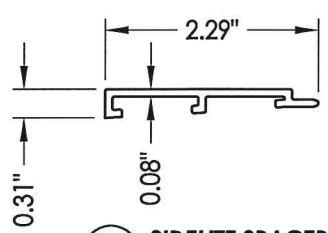

**66 SIDELITE SPACER**  
Outswing

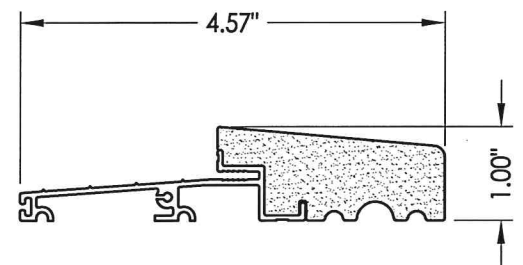

**27 OUTSWING THRESHOLD**

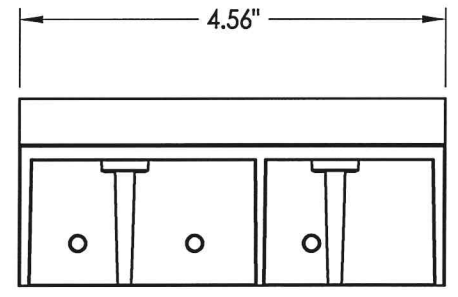

**19 SILLKEY DETAILS**  
Optional

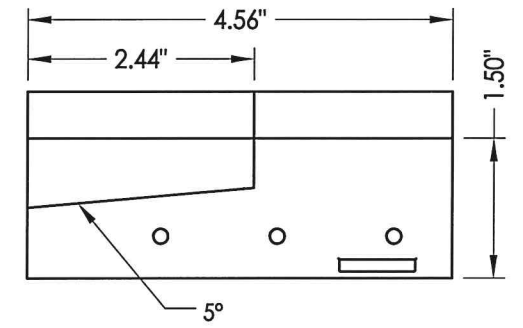
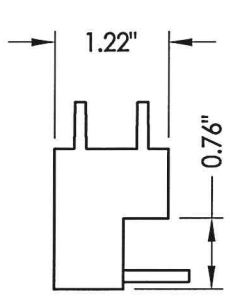

SILLKEY, LEFT  
SCALE: NONE

SILLKEY, RIGHT  
SCALE: NONE

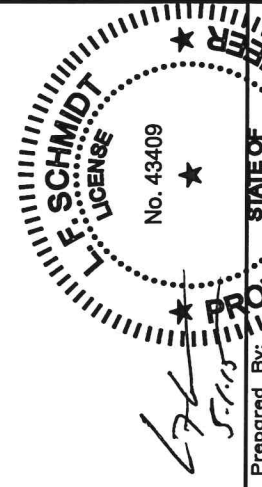
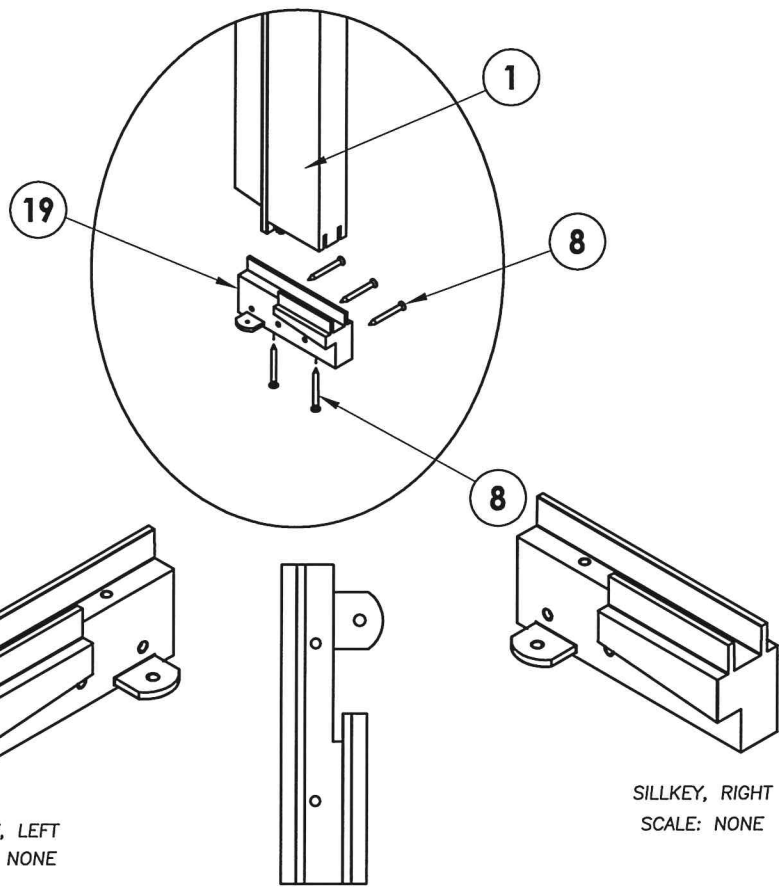

Documents Prepared By:  
Lyndon F. Schmidt  
P.E. No. 43409

**R.W.** BUILDING CONSULTANTS, INC.  
P.O. Box 230, Valrico, FL 33595  
Phone No.: 813.659.9197  
FBPE C.A. No. 9813

PRODUCT: TRINITY GLASS INT'L		PART OR ASSEMBLY: COMPONENTS	
NO.	DATE	JK	BY
1	03/02/15	UPDATE TO 5TH ED. (2014)	FBC
REVISIONS			
DATE: 02/27/12			
SCALE: N.T.S.			
DWG. BY: JK			
CHK. BY: LFS			
DRAWING NO.: FL-15255.2			
SHEET 15 OF 16			

R:\Clients\Trinity PERMANENT\Florida Product Approvals\FL-15255\C - Drawings\FL-15255\FL-15255.1-4.dwg, 16.2

BILL OF MATERIALS		
ITEM #	DESCRIPTION	MATERIAL
A	1X BUCK SG >= 0.55	WOOD
B	2X BUCK SG >= 0.55	WOOD
C	1/4" MAX. SHIM SPACE	-
D	1/4" X 2-3/4" PFH ELCO OR ITW CONCRETE SCREW	STEEL
E	MASONRY - 3,000 PSI MIN. CONCRETE CONFORMING TO ACI 301 OR HOLLOW BLOCK CONFORMING TO ASTM C90	CONCRETE
F	1/4" X 3-3/4" PFH ITW CONCRETE SCREW	STEEL
H	1/4" X 3-1/4" PFH ITW CONCRETE SCREW	STEEL
J	#9 X 2-1/4" PFH WS	STEEL
L	#8 X 2-1/2" PFH WS	STEEL
M	3/16" X 3-1/4" PFH ITW CONCRETE SCREW	STEEL
P	1/4" X 2-3/4" PFH ELCO OR ITW CONCRETE SCREW	STEEL
Q	3/16" X 2-1/4" PFH ITW CONCRETE SCREW	STEEL
1	JAMB (FINGER-JOINT PINE - SG >= 0.42)	WOOD
1A	STRIKE JAMB - FINGER-JOINT PINE (5-1/4") - SG >= 0.42	WOOD
2	JAMB	FIBERGLASS/COMP
8	#6 X 1-1/4 PFH DRYWALL SCREW	STEEL
9	#9 X 2-1/4" PFH WOOD SCREW	STEEL
12	WEATHER STRIP QEBD650 Q-LON	-
18	3.983" X 4.0" HINGE MIN 0.098" THICK	STEEL
19	SILLKEY	PC/ASA
22	DEADBOLT STRIKE PLATE	STEEL
23	STRIKE PLATE	STEEL
24	#9 X 5/8" PFH WS	STEEL
25	OUTSWING HIGH-DAM THRESHOLD ALUMINUM W/ COMPOSITE SUBSTRATE	ALUM./ COMP.
26	#9 X 1.0" PFH WS	STEEL
27	OUTSWING THRESHOLD ALUMINUM W/ COMPOSITE SUBSTRATE	ALUM./ COMP.
40	DOOR PANEL - SEE DOOR PANEL DETAIL SHEET FOR CONSTRUCTION DETAILS	-
60	SIDELITE PANEL - SEE SIDELITE PANEL DETAIL SHEET FOR CONSTRUCTION DETAILS	-
62	QUARTER ROUND	
63	#8 X 2-1/4" PFH WOOD SCREW	STEEL
64	#8 X 2" PFH WOOD SCREW	STEEL
67	INTEGRAL MULLION - FINGER JOINT PINE (SG >= 0.42)	WOOD
69	MULLION BASE KIT	PC/ASA

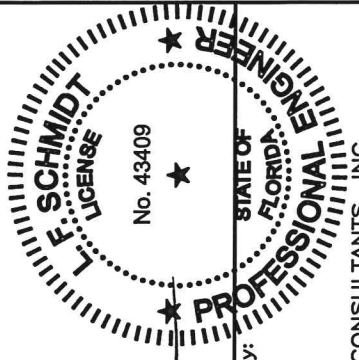

67  
5-1-15

Documents Prepared By:  
Lyndon F. Schmidt  
P.E. No. 43409

R.W.  
BUILDING CONSULTANTS, INC.  
P.O. Box 230, Vairico, FL 33595  
Phone No.: 813.659.9197  
FBPE C.A. No. 9813

PRODUCT: TRINITY GLASS INT'L  
PART OR ASSEMBLY: BILL OF MATERIALS

NO.	DATE	JK	BY
1	03/02/15	UPDATE TO 5TH ED. (2014) FBC	

DATE: 1/18/12  
SCALE: N.T.S.  
DWG. BY: JK  
CHK. BY: LFS  
DRAWING NO.: FL-15255.2  
SHEET 16 OF 16